

# bar-agturn®

Pneumatic rotary actuator  
Type GD/GS

**Translation of the original operating manual**



# Table of Contents

<b>1.</b>	<b>General information .....</b>	<b>5</b>
1.1	Reference documents.....	5
1.2	Validity of the operating manual.....	5
1.3	Notes to operating manual .....	5
1.3.1	Signal words and symbols .....	5
1.3.2	Explanation of the structure of the safety instructions.....	7
1.3.3	Descriptions in figures.....	7
1.4	Responsibility of the operator .....	7
<b>2.</b>	<b>Safety .....</b>	<b>8</b>
2.1	General Safety Instructions .....	8
2.2	Intended use.....	8
2.3	Foreseeable misuse.....	8
2.4	Organizational measures .....	8
2.4.1	Modification or changes to the rotary actuator.....	8
2.4.2	Replacement of defective parts.....	8
2.5	Protective equipment.....	8
2.6	Personnel qualification .....	9
2.7	Dangers when handling the pneumatic rotary actuator.....	11
2.7.1	Dangers during assembly and disassembly.....	11
2.7.2	Dangers during functional checks, commissioning and operation.....	14
2.7.3	Dangers when used in explosion-protected areas .....	15
<b>3.</b>	<b>Product description .....</b>	<b>16</b>
3.1	Overview of different models .....	16
3.2	Type plate.....	18
3.3	Product and function description.....	19
3.4	Operating and display elements .....	20
3.5	Accessories.....	21

<b>4.</b>	<b>Transport and storage .....</b>	<b>21</b>
4.1	Scope of delivery .....	21
4.1.1	Incoming goods inspection.....	21
4.2	Transport, packaging and storage.....	22
<b>5.</b>	<b>Installation .....</b>	<b>23</b>
5.1	Installation conditions.....	23
5.2	Before installation .....	23
5.3	Installation of the valve .....	24
5.4	Installation of the pneumatic connection.....	25
5.5	Pressure test of the pipe section .....	25
<b>6.</b>	<b>Commissioning and operation .....</b>	<b>26</b>
6.1	General information for commissioning of different variants.....	26
6.2	Setting the end positions.....	26
6.2.1	Adjustment of swivel angle for mounting variants F/E .....	28
6.2.2	Adjustment of swivel angle for mounting variants G/H .....	29
6.2.3	Adjustment of the swivel angle via the cover.....	29
<b>7.</b>	<b>Maintenance and repair .....</b>	<b>30</b>
<b>8.</b>	<b>Troubleshooting .....</b>	<b>30</b>
<b>9.</b>	<b>Repair and spare parts .....</b>	<b>31</b>
9.1	Type GD-032 (schematic diagram).....	31
9.2	Type GS-075 (schematic diagram).....	32
<b>10.</b>	<b>Disassembly .....</b>	<b>33</b>
10.1	Disassembly of the rotary actuator .....	33
<b>11.</b>	<b>Disposal .....</b>	<b>33</b>

<b>12. EU Declarations .....</b>	<b>34</b>
12.1 Declaration of incorporation according to Directive 2006/42/EC.....	34
12.2 ATEX Declaration of Conformity .....	35
<b>13. Annex / Technical data .....</b>	<b>36</b>

# 1. General information

This operating manual is a part of the product. The operating manual must be kept for the entire life of the product and must be passed on to each subsequent owner of the product.

The operating manual must always be available at the place of operation.

## 1.1 Reference documents

This manual, the data mentioned and design data sheets, additional assembly and maintenance instructions as well as further information – also in other language versions, can be obtained from:

bar pneumatische  
Steuerungssysteme GmbH

Auf der Hohl 1  
53547 Dattenberg

Tel.: +49 (0)2644-9607-0  
Fax: +49 (0)2644-960735

Email: [bar-info@wattswater.com](mailto:bar-info@wattswater.com)  
[www.bar-gmbh.de](http://www.bar-gmbh.de)

## 1.2 Validity of the operating manual

This operating manual is valid for the following bar-agturn rotary actuators starting from year of construction 2019:

- Type GD-032 till 040
- Type GD/GS-052 till 400

## 1.3 Notes to operating manual

The safety and hazard statements in the document are intended for your protection, the protection of third parties and the protection of the product. The instructions must therefore be observed.

### 1.3.1 Signal words and symbols

#### **DANGER**

... indicates a hazard that, if not avoided, will result in death or serious injury.

#### **WARNING**

... indicates a hazard that, if not avoided, could result in death or serious injury.

#### **CAUTION**

... indicates a hazard which, if not avoided, could result in minor or moderate injury.

## NOTE

... indicates important information (e.g. Material damage) but not hazards.



### Electric voltage!

The text passages marked with this symbol inform you about dangerous situations with danger to life and health of persons due to electrical voltage.



### Corrosive substances!

The text passages marked with this symbol inform you about dangerous situations caused by corrosive substances.



### Hot surface!

The text passages marked with this symbol inform you about dangerous situations with a risk of burns due to hot surfaces.



### Cold surface!

The text passages marked with this symbol inform you about dangerous situations with a risk due to cold surfaces.



### Suspended load!

The text passages marked with this symbol inform you about dangerous situations with a risks due to suspended load.



### Hand injuries!

The text passages marked with this symbol inform you about dangerous situations resulting in hand injuries caused by bruising or punching. The activities described in the relevant text passage must be performed with the utmost care to avoid dangerous situations and resulting injuries such as loss of limbs.



### Use head protection!

Notes with this symbol indicate that a head protection must be worn.



### Use protective clothing!

Notes with this symbol indicate that a protective clothing must be worn.



### Use hand protection!

Notes with this symbol indicate that a hand protection must be worn.

### 1.3.2 Explanation of the structure of the safety instructions

A safety instruction is initiated with a signal word describing the severity of the danger („Chapter 1.3.1 Signal words and symbols“).

#### **WARNING**

##### **Type or source of danger (possibly with warning signs according to DIN EN ISO 7010)**

Consequences in case of not following the instruction

- Avoidance of danger

### 1.3.3 Descriptions in figures

The figures in this operating manual are intended to help you understand the facts and procedures.

The descriptions in the figures are exemplary and may differ slightly from the actual appearance of your product.

### 1.4 Responsibility of the operator

- The installation, electrical and pneumatic connection as well as the commissioning of the product may only be carried out by qualified personnel in accordance with the instructions described in this operating manual.
- The product may only be operated and maintained by personnel of the legal minimum age and the corresponding personnel qualification.
- This operating manual is an integral part of the product and must be available to the personnel at all times. This operating manual must be read and understood before the first commissioning.
- The operating and technical personnel must be instructed about safety devices of the product as well as safe working methods.
- The product may only be operated in perfect condition. No safety devices may be removed or disconnected.

## 2. Safety

### 2.1 General Safety Instructions

Personnel assigned to work on the rotary actuator must read the operating instructions before starting work and, in particular, understand the chapter "Safety" before starting work. This is particularly valid for personnel working only occasionally on the rotary actuator.

### 2.2 Intended use

- The product is designed for use in process engineering systems.
- The product is used for the automatic actuation of industrial valves continuously moving between the end positions by means of compressed air. Operation with other gases or liquids must be approved in writing by the manufacturer.
- The product is suitable for the automation of valves in order to shut-off liquids and gases in pipelines and containers.
- The operating values, limit values and setting data specified in the operating instructions and the corresponding data sheet must not be altered without the written permission of the manufacturer.
- Intended use also includes the observance of these operating instructions.

### 2.3 Foreseeable misuse

Any use other than that described in „Chapter 2.2 *Intended use*“ and any use not approved by the manufacturer is considered as unintended!

### 2.4 Organizational measures

#### 2.4.1 Modification or changes to the rotary actuator

The unauthorized modification and/or changes to the product is prohibited for safety and licensing reasons (CE). Changes to the product may only be made after consultation and written approval from the manufacturer.

#### 2.4.2 Replacement of defective parts

Replace parts of the quarter-turn actuator that are not in perfect condition immediately with original spare parts.

Please note that only original spare and wear parts of bar GmbH are to be used.

In the case of usage of the third-party parts, it is not ensured that they are designed and manufactured to suit the requirements.

### 2.5 Protective equipment

If necessary, the protective equipment shall be used. Keep your hair and clothing away from moving parts. If necessary, wear a hairnet and do not wear jewelry such as necklaces and rings!





### Use head protection!

Wear suitable head protection during transport.



### Use protective clothing!

Wear suitable protective clothing during commissioning, maintenance and troubleshooting.



### Use hand protection!

Wear suitable hand protection during transport, commissioning, maintenance and troubleshooting.

- Instructed persons must operate the rotary actuator and be able to detect possible damage and dangers on the rotary actuator.
- Instructed persons with technical training must also be aware of the dangers of handling pressurized equipment, hot and cold surfaces, harmful and hazardous materials and the process of installing and removing the valves in a process line, the specific and potential risks of the process and the most important safety regulations.
- Trained electricians must read and understand electrical circuit diagrams, commission, put electric machines into operation, service and maintain them, wire switch and control cabinets, install control software, ensure the functionality of electrical components and identify potential hazards in handling electrical and electronic systems.
- Trained pneumatic specialists must read and understand pneumatic circuit diagrams, put pneumatic systems into operation, service and maintain them, disconnect and connect pneumatic hoses, ensure the proper functioning of pneumatic components, assess the work performed on the pneumatic system and identify potential hazards.

## 2.6 Personnel qualification

Only trained or instructed personnel who has known and understood the operating instructions as well as the possible dangers of the rotary actuator is allowed to work with the rotary actuator. The responsibility of the personnel for operation, maintenance and repair must be clearly defined by the operator.

Personnel to be trained, instructed or undergoing training may work on the rotary actuator only under the constant supervision of an experienced person.

The individual activities on the rotary actuator require different personnel qualifications which are listed in the following table. The different qualifications are characterized by the following skills and knowledge:

Read this table as follows:

"The electrical installation requires the qualification of a qualified electrician."

Activities	Instructed persons	Instructed persons with technical training	Electricians	Pneumatic specialists
Installation		X		
Electrical installation			X	
Pneumatic installation				X
Setting and equipping		X		
Commissioning		X		
Troubleshooting	X			
Cleaning	X			
Troubleshooting, repair and maintenance of mechanics		X		
Troubleshooting, repair and maintenance of electrics			X	
Troubleshooting, repair and maintenance of pneumatics				X
Functional checks		X		
Shutdown	X		X	
Transport	X			
Disposal	X			

Tab. 2-1 Overview of the required personnel qualifications

## 2.7 Dangers when handling the pneumatic rotary actuator

This product of bar GmbH is built according to the state of the art and the recognized safety rules. Nevertheless, there remains a residual risk and may cause dangers to the life and limb of the user or third parties or impairments of the product and other material assets in use, if:

- the product is not used as intended,
- the product is operated or repaired by untrained personnel,
- the product is improperly changed or modified and/or
- the safety instructions are not observed.

Eliminate faults that may affect safety.

### 2.7.1 Dangers during assembly and disassembly

#### WARNING



#### Electric voltage!

There is danger to life when working on electrical components.

- The electrical connections may be performed only by qualified electricians.
- When working on the components, have the voltage released by a qualified electrician and secured against being switched on again.
- Let a qualified electrician check that no current is present.

#### WARNING



#### Corrosive substances!

Depending on the type of medium, there may be danger to life when in contact with the medium.

- Check the properties of the medium.
- Protect yourself and your environment from harmful or toxic substances.
- Follow the safety instructions in the manufacturer's safety data sheets.
- Make sure that no medium can get into the pipeline, valves during assembly work.
- Make sure that personnel working with the valves and installing or repairing the valves have received appropriate training.

#### WARNING



#### Very cold and hot surfaces!

• The body of the valve can become very cold or very hot during operation.



- Wear protective gloves and protective clothing to protect against frostbite or burns.
- Make sure that personnel working with the valves and installing or repairing the valves have received appropriate training.

**⚠ WARNING**



**Danger of crushing hands and other body parts!**

There is a risk of injury during assembly/disassembly by movements of the ball. The shut-off body (e.g. ball or disc) of the valve works as a separating element. It makes no difference whether a rotary actuator is mounted or not. The position of the ball may change during transport or handling of the valve.

- Keep hands and fingers away with the compressed air supply connected.
- Always disconnect the compressed air supply from the rotary actuator before carrying out maintenance and repair work on the valve and when installing and removing the ball valve from the pipeline.
- Pay attention to movements of the ball.
- Keep hands, other body parts, tools and other objects out of the swivel range of the ball. Do not leave any foreign objects inside the pipeline.
- Perform works carefully when assembling, disassembling and sampling.

**⚠ WARNING**

**Flying parts!  
Splashing medium!**

There is a risk of injury when the valve is removed under pressure or with present medium. The disassembly or removal of a pressurised valve causes an uncontrolled pressure drop.

- Do not disassemble or remove the valve from the pipeline as long as the valve is pressurized.
- Always isolate the respective valve in the piping system.
- Depressurise the valve and remove the medium before working on the valve and the rotary actuator.

**⚠ WARNING**

**Ejected parts!**

When adjusting the rotary actuators and when the rotary actuator is opened under pressure, there is a risk of parts being ejected!

- Always disconnect the compressed air supply before maintenance, disassembly and repair!
- Never set the mechanical end positions on the actuator as long as there is pressure on connection 2 or 4.
- Make sure the pinion of the rotary actuator is moving in the correct direction.

### **WARNING**

#### **Welding works!**

Welding and flying sparks can cause fires.

- Make sure that the prescribed safety precautions are taken before carrying out welding works.
- Inform the relevant employees such as security officer, shift leader, company fire brigade.
- Apply for a written welding permit.
- Provide fire extinguishers.

### **WARNING**

#### **Uncontrolled start-ups**

There is a risk of injury if pneumatic rotary actuators create a very high torque during actuation or by spring force.

- Secure the rotary actuator against any unintentional start-up or unexpected spinning.
- Work on the pneumatic rotary actuators in a prudent way.
- In case of single-acting rotary actuators (type GS), make sure that the rotary actuator is in the home position (relaxed springs) when disassembling.

### **CAUTION**

#### **Hand injuries!**

When mounting the rotary actuator on the valve spindle, the rotary actuator is pushed to the connection point/flange of the valve.

When disassembling the rotary actuator or removing the rotary actuator from the valve spindle, the parts can slip down.

There is danger of crushing the hands!

- Carefully pull off the rotary actuator.
- Keep fingers and hands away from the connection point.

### **NOTE**

#### **Material damage to valve spindle!**

Material damage can occur if you use built-on rotary actuators as levers.

- Do not use built-on actuators as levers as they could damage the actuator and the valve.

## 2.7.2 Dangers during functional checks, commissioning and operation

### **WARNING**

#### **Bursting parts! Escaping media!**

There is danger to life if the maximum permissible pressure and temperature ranges of the valve are insufficient for the operating conditions of the system. There is a risk of injury and the risk of material damage by wrongly selected materials.

In addition, there is a risk of damage to the piping system.

- Only use the valves that are designed for the operating conditions.
- Make sure that the selected materials of the parts of the valve coming in contact with the medium are suitable for the media used.

### **WARNING**



#### **Escaping medium!**

There is a risk of injury from escaping medium as a result of leaks (scalding, hazardous substances).



- Protect yourself from thermal or chemical burns.
- Leave the danger area in case of leakage and keep third persons out of the danger zone. Use appropriate barriers or name supervisors.

### **WARNING**



#### **Danger of being pulled in, danger of crushing and locking**

Danger due to moving parts of the machine/valve which can be accessed through assembly, disassembly, removable covers at openings for functional checks, sampling, etc. and through automatically operated valves.

- Keep hands and fingers away with the compressed air supply connected.
- Please note that single-acting rotary actuators can move the valve to the "open" or "closed" position when closing or disconnecting the compressed air supply.
- Perform works carefully when commissioning, making functional checks and sampling.

## WARNING



### Risk of burns!

Devices and system components can become very hot during operation.

- Wear protective gloves and protective clothing to protect against burns.
- At operating temperatures > 65°C a short contact (approx. 1s) of the skin with the surface of the machine/valve may cause burns (DIN EN ISO 13732-1).
- At operating temperatures = 60 °C a long contact (approx. 3s) of the skin with the surface of the machine/valve may cause burns (DIN EN ISO 13732-1).
- At operating temperatures 55 °C – 60 °C a long contact (approx. 3S to 10s) of the skin with the surface of the machine/valve may cause burns (DIN EN ISO 13732-1).

## CAUTION

### Self-loosing components!

Components and fasteners may become loose if not properly installed.

- Observe the information on tightening torques in this operating manual.
- Check the tightening torque of screw connections and tighten with the torque wrench, if necessary.

## CAUTION

### Noise!

When venting the pneumatic rotary actuator, noise can be hazardous to health.

- Use silencer at vent port or take other personal protection measures.

## 2.7.3 Dangers when used in explosion-protected areas

## DANGER

### Danger of explosion

An explosion can occur if the following protective measures are not observed:

- Establish an internal electrically conductive equipotential bonding between the rotary actuator and all metal mounting parts and the pipeline.
- Protect the surfaces against inadmissibly high temperatures due to solar radiation. Shading covers can possibly be required.
- When selecting the pneumatic valves and the end position feedbacks, pay attention to the combination with Ex-approved products.
- Avoid sparking when using the tool.
- Avoid dust accumulation.
- Do not install rotary actuators in pit-like cavities if there is a predictable dust accumulation.
- Do not carry out leak detection with ultrasonic transmitters.

### 3. Product description

#### 3.1 Overview of different models



Fig. 3-1 Product variants bar-acturn GD-032 till 040, GD/GS-052 till 270, GD/GS-300 till 400

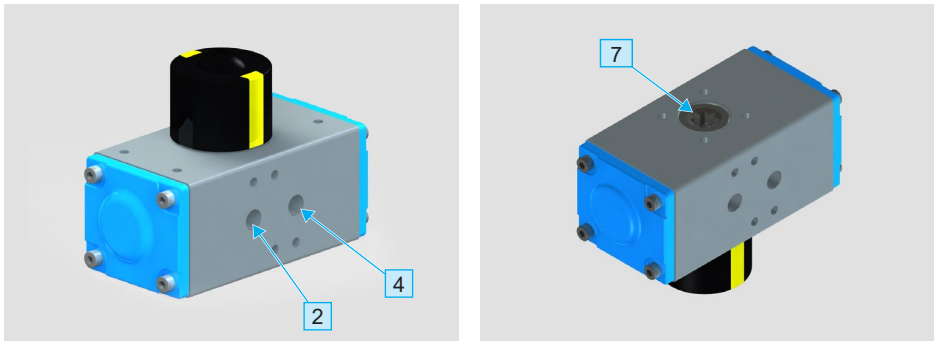

Fig. 3-2 bar-acturn GD-032 overview of components (left: top view, right: bottom view)

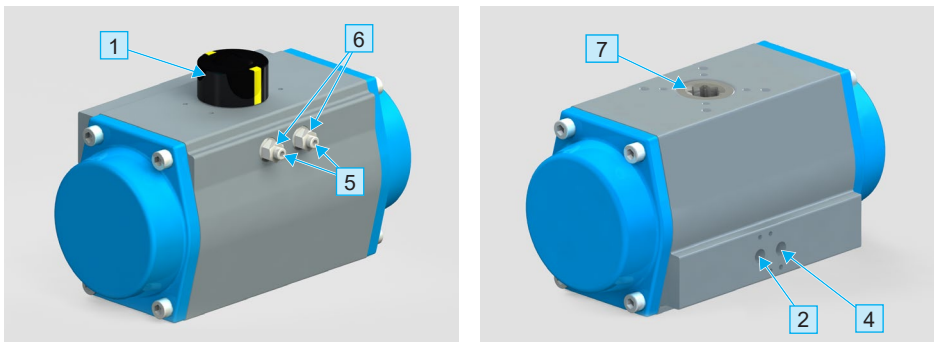

Fig. 3-3 bar-acturn GD/GS-125 overview of components (left: top view, right: bottom view)



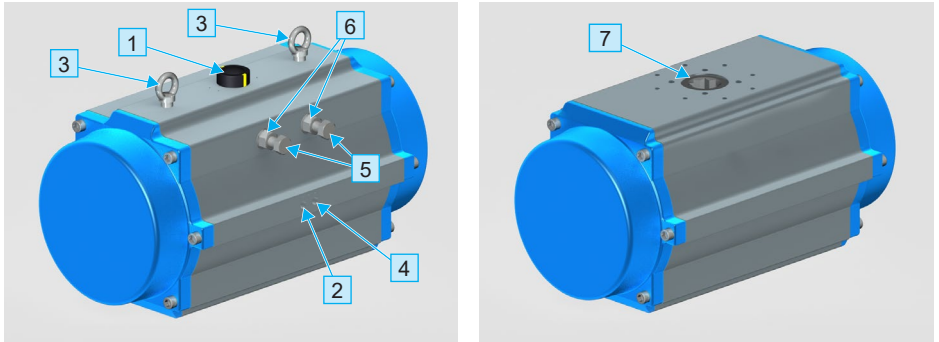

Fig. 3-4 bar-agturn GD/GS-300 overview of components (left: top view, right: bottom view)

### Legend

- |   |   |
|---|---|
| <ol style="list-style-type: none"> <li>1. Position indicator and interface to the end position feedback as well as position controllers according to VDI/VDE 3845 (Namur)</li> <li>2. Pneumatic interface connection of the actuator according to VDI/VDE 3845 (Namur)</li> <li>3. Ring nut from GD/GS-160</li> </ol> | <ol style="list-style-type: none"> <li>4. Pneumatic interface connection of the actuator according to VDI/VDE 3845 (Namur)</li> <li>5. Adjusting screws</li> <li>6. Lock nuts of the adjusting screws</li> <li>7. Valve interface according to EN ISO 5211</li> </ol> |
|---|---|

### 3.2 Type plate

The following figures and the legend contain examples of different versions of a pneumatic rotary actuator.

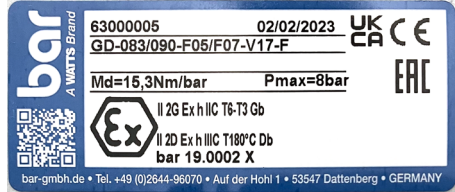
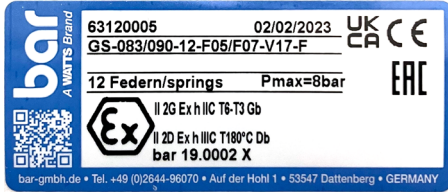

Fig. 3-5 Type plate of single-acting and double-acting rotary actuator

#### Legend (example values)

63120005/63000005	bar article number
GD-183/090-F05/F07-V17-F	Article/order designation (see data sheet)
12 springs	Number of safety springs for single-acting actuators
Md=15.3 Nm/bar	Torque per 1 bar of control pressure
Pmax=8 bar	Permis. max. control pressure for the pneum. rotary actuator
Last line	ATEX marking and date of manufacture (year of construction)

### 3.3 Product and function description

The pneumatic rotary actuator bar-acturn is actuated exclusively with compressed air or other suitable control media via control valves. The swivel angle range is 90° and can be set as standard in both end positions (0° and 90°) from +5° to -5°.

The pneumatic rotary actuator is delivered as required in a double- and single-acting function (with safety springs which return the rotary actuator to the basic position). The respective valve position is indexed via the standard optical position indicator (see Fig. 3-11 and Fig. 3-12). The end position feedback device can be ordered as an accessory.

The sizes GD-032 till 40 are designed only as double-acting devices.

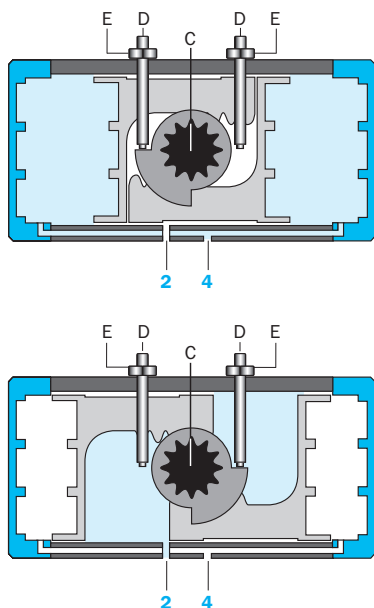

Fig. 3-6 Rotary actuator bar-acturn function „double-acting“ GD-032 till 210

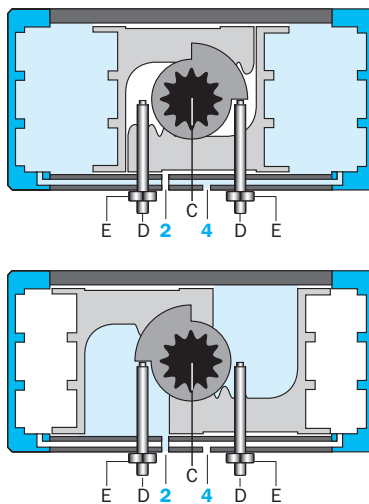

Fig. 3-7 Rotary actuator bar-acturn function „double-acting“ GD-240 till 400

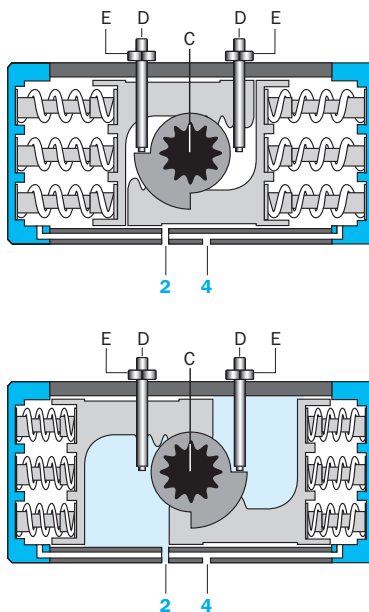

Fig. 3-8 Rotary actuator bar-acturn function „single-acting“ GS-052 till 210

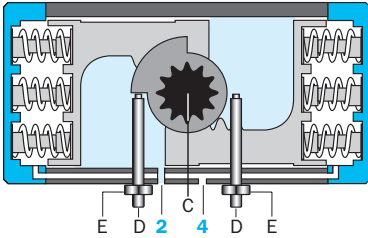
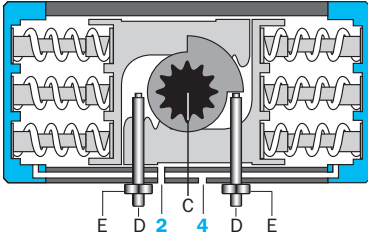

Fig. 3-9 Rotary actuator bar-actuator function „single-acting“ GS-240 till 400

On request, the rotary actuator can be equipped with an option for stroke adjustment via the cover. Included in the series for drives with swivel angle 120°/135°/180°.

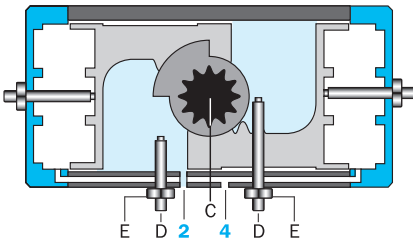

Fig. 3-10 Stroke limitation via cover

### 3.4 Operating and display elements

The positions of the valve are indicated by an optical position indicator mounted on the rotary actuator. The yellow and black clips can be remounted according to the installation situation.



Fig. 3-11 Operating and display elements of the rotary actuator bar-actuator  
Longitudinal design = closed position  
Transverse design = open position



Fig. 3-12 Operating and display elements of the rotary actuator bar-actuator  
Longitudinal design = open position  
Transverse design = closed position

In case of **longitudinal design** the position indicator shall be mounted as follows:

- Fig. 3-11 indicates the closed position
- Fig. 3-12 indicates the open position

Optionally the rotary actuator bar-acturn can be mounted **transversely to the pipe-line**. The position indicators are mounted as follows:

- Fig. 3-11 indicates the open position
- Fig. 3-12 indicates the closed position

#### NOTE

Make sure that the optical position indicator together with a ball valve always corresponds to the ball bore or, in the case of a butterfly valve, always corresponds to the disc.

### 3.5 Accessories

#### DANGER

##### Danger of explosion

An explosion can occur if components are operated with insufficient protection class and without approved explosion protection.

- When selecting the pneumatic valves and the accessories, pay attention to the combination with Ex-approved products.

Contact your bar customer service for selection of the right accessories:

- Throttle plates
- Silencer
- End position feedback devices
- Solenoid valves
- Positioner

## 4. Transport and storage

### 4.1 Scope of delivery

- Pneumatic rotary actuator bar-acturn
- Possibly ordered accessories

#### 4.1.1 Incoming goods inspection

The following items must be checked at the time of delivery:

- Does the number of delivered transport containers correspond to the delivery note?
- Is the packaging free of visible damage?
- Are the product and accessories free of visible damages?
- Are there any evidences of not gentle handling during the transport (e.g., burns, scratches, colour)?

To have all the right for claim against the transport company, you have to document the possible external transport damages (e.g. with photographs and a written protocol) before unpacking the product.

bar GmbH is not responsible for transport damages and can take over no liability for that.

## 4.2 Transport, packaging and storage

### DANGER



#### Suspended load!

When transporting, e.g. with a crane, there is a risk that parts fall down and people are seriously injured.

- Never exceed the permissible load of the hoisting equipment used.
- Use only suitable, approved and undamaged lifting slings for transport.
- If you connect the slings to the rotary actuator, they may only be used to transport the rotary actuator and not for the entire control device.
- Connect the slings so that the products can not be damaged.
- Exercise the utmost care when handling and balancing the load.
- Perform the works with constant eye contact with the load.
- Do not stay under or near the lifted load.
- Keep third persons out of the danger zone. Use appropriate barriers or name supervisors.

### NOTE

If lifting slings are required for transport, they must be connected in such a way that the products are not damaged.

Lifting slings are mounted at the factory from size 160 (type GD/GS-160). The supplied slings are intended solely for the transport of the products to which they are mounted.

The products must be handled, transported and stored with care:

- There is no liability of the manufacturer for transport within the customer's territory or to the individual places of use.
- The products should be transported in their original packaging or on a pallet (or similarly supported) to the installation site and unpacked immediately before installation.
- When storing before installation, keep the products in a closed room and protect them from harmful influences such as dirt or moisture.
- The products must be stored in their original packaging and, if necessary, with the appropriate protective covers.
- In case of a longer storage period, the pneumatic rotary actuator must be operated at least once a year.
- Proper disposal of the packaging is the responsibility of the customer.

## 5. Installation

### WARNING

#### Installation works

There is a risk of injury if this product is not properly installed, disassembled and put into operation.

- Make sure the personnel has received the appropriate training.
- Observe the safety instructions in „Chapter 2. Safety“.

### NOTE

Check the technical parameters, in particular pressure and temperature, and the electrical voltage of the control valve before installing or commissioning the rotary actuator.

### 5.1 Installation conditions

The minimum space requirement can be found in the dimension drawing or dimension table („Chapter 13. Annex / Technical data“).

### 5.2 Before installation

Observe the following points before installation:

- The dew point of the control medium must be min. 10 °C lower than the lowest operating temperature! The max. temperature of the control medium is 45 °C!
- The rotary actuator is not suitable for accepting external lateral forces on the pinion as well as for permanent torsional vibrations in the end positions.

- When operating valves, considerable kinetic energy can be generated which is transmitted to the actuator. The user must ensure that the rotary actuator is adequately protected and that the below-mentioned switching times for soft-sealing flaps and standard ball valves for pure 90° rotary movement are not exceeded.

The following minimum switching times for the rotary movement of 90° must be observed:

Type (GD/GS)	Switching times
032 till 063	0,3 sec
075 till 125	0,7 sec
140 till 210	1,0 sec
240 till 400	2,0 sec

**Tab. 5-1 bar-agturn minimum times for the rotary movement of 90°**

The switching time can be reduced and adjusted by using silencers or throttle plates from our range of accessories.

We recommend hydraulic damping for critical applications.

For other valve types, in particular large-volume valves with low torque requirement, the operating conditions of the rotary actuator must be agreed with the manufacturer. We will be delighted to advise you.

### 5.3 Installation of the valve

MV*	Basic position		Swivel direction	Switched position	
	Piston position	Position indicator		Piston position	Position indicator
F					
E					
G					
H					

\* MV = Mounting variants

**Tab. 5-2 Mounting variants for rotary actuator bar-agturn (see also type plate)  
View from above**

#### Left-turning mounting variants F/E

Left-turning means that the actuator rotates counterclockwise when pneumatic port 2 is pressurized.

#### Right-turning mounting variants H/G

Right-turning means that the actuator rotates clockwise when pneumatic port 2 is pressurized.

#### Left-turning opening - Right-turning closing

In general, valves are opened by turning to the left, i.e. counterclockwise, and closing by turning to the right, i.e. clockwise.

With the appropriate selection of mounting variant you can thus ensure with single-acting rotary actuators that the valve is closed (spring force closing: F/E) or opened (spring force opening: H/G) in case of pressure failure.

Make sure that the optical position indicator together with a ball valve or flap always corresponds to the ball bore/disc.

Make sure that the maximum torques of the flange pattern used are not exceeded for the sake of design and operation!

Connecting surfaces must be free from oil and grease, clean and dry.

1. Place the rotary actuator on the valve spindle (7). If necessary, install prior required components such as, for example, shaft adapter, reduction, mounting bridges and/or centering.
2. Slightly grease the connecting bolts.
3. Tighten the connecting screws on the flange pattern according to *Tab. 5-3*.

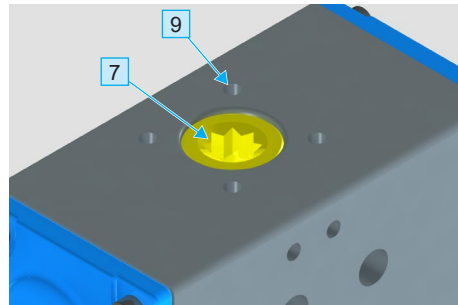

**Fig. 5-1 View on rotary actuator from bottom = valve interface**

- 7 Installation of the valve spindle / shaft adapter
- 9 Installation of the connecting screws



Observe the following tightening torques when installing connecting bolts:

Flange pattern	Screw size	Tightening torque [Nm]
F03	M5	6
F04	M5	10
F05	M6	10
F07	M8	25
F10	M10	49
F12	M12	85
F14	M16	145
F16	M20	310
F25	M16	145

Tab. 5-3 Tightening torques for connecting screws of rotary actuator – valve

## 5.4 Installation of the pneumatic connection

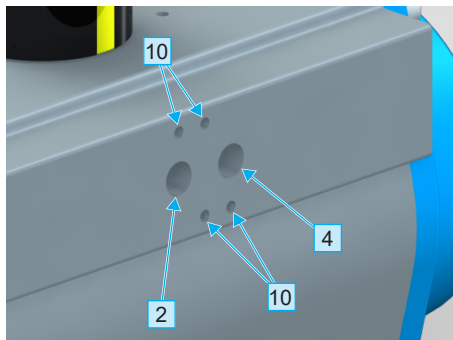

Fig. 5-2 Pneumatic connections of the rotary actuator bar-acturn

- 2** Pneumatic connection
- 4** Pneumatic connection
- 10** Threaded hole M5

Make sure that plugs or end caps are removed at the pneumatic connections 2 and 4, if necessary.

The single-acting rotary actuators are equipped with a silencer in the pneumatic connection (4) at the factory. Remove this before you connect NAMUR control valve.

Pneumatic connection for single-acting rotary actuators:

- Remove silencer in the pneumatic connection (4).
- Connect the pneumatic connection (2) to the compressed air supply line.

Pneumatic connection for double-acting rotary actuators:

- Connect the pneumatic connections 2 and 4 to the compressed air supply lines.

## 5.5 Pressure test of the pipe section

The following must be observed when making the pressure test of a pipe section with installed valves:

Carefully rinse newly installed piping systems to flush out any foreign objects.

Valve opened:

- The test pressure must not exceed the value of  $1.5 \times PN$  as marked on the housing.

Valve closed:

- The test pressure must not exceed the value of  $1.1 \times PN$  as marked on the housing.

## 6. Commissioning and operation

### 6.1 General information for commissioning of different variants

The bar-acturn rotary actuator (except for size 032) is equipped as standard with a mechanical end position adjustment on both sides.

The size GD-032 has a fixed stop at 0° and 90°.

For bar ball valves with pneumatic actuator, the end positions are pre-adjusted to 0° and 90° at factory. In case of bar GmbH automated butterfly valves with pneumatic actuator, the end positions are set at the factory in such a way that the butterfly valve opens approx. 4° when closed and 90° when opened. The automated valves are checked for function.

If you would like to make a new adjustment or alignment of the mechanical end positions on the rotary actuator bar-acturn, please observe the adjustment range of the mechanical swivel angle according to *Fig. 6-1* as well as the following notes and descriptions.

Actuator size GD-040 till 400 are also available with an additional adjusting screw in the cover to further limit the swivel angle range.

In case of actuators with a swivel angle of 120°/135°/180°, the end location of the switch position is only limited by the cover.

### 6.2 Setting the end positions

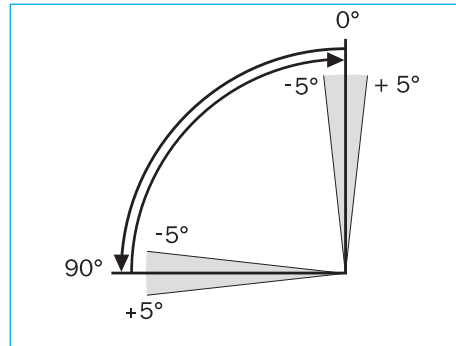

**Fig. 6-1** Adjustable mechanical swivel angle range of the bar-acturn version 90° from size GD-040, GD/GS-052 till 400

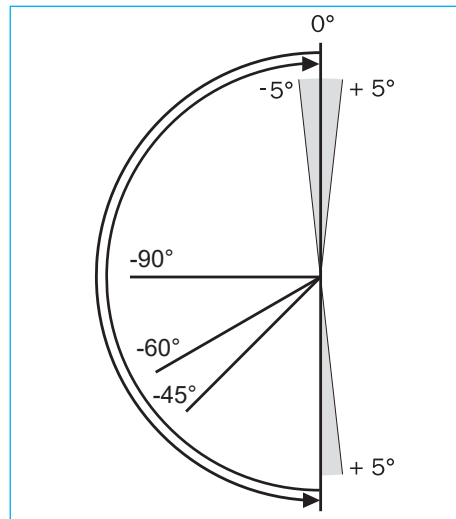

**Fig. 6-2** Adjustable mechanical swivel angle range of the bar-acturn version 120°/135°/180° from size GD-040, GD/GS-052 till 210

**⚠ WARNING**

**Ejected parts!**

When adjusting the rotary actuators and when the rotary actuator is opened under pressure, there is a risk of parts being ejected!

- Always disconnect the compressed air supply before maintenance, disassembly and repair!
- Never set the mechanical end positions on the rotary actuator as long as there is pressure on connection 2 or 4.
- Make sure the pinion of the rotary actuator is moving in the correct direction.

**Basically, the following applies:**

The adjusting screws have a right-hand thread.

- Screwing in = turning clockwise reduces the swivel angle.
- Screwing out = turning counterclockwise increases the swivel angle.

For safety reasons, the adjusting screws may be screwed in or out by a maximum of 1-2 turns depending on the actuator size.

Turning in or out by 1 turn corresponds to an angle adjustment of up to 5°.

The adjusting screws must only be screwed out so far that the screw heads protrude only a few millimeters beyond the lock nut on the actuator housing.

When screwing in, make sure that the adjusting screws remain completely in the thread of the lock nut on the actuator housing.

Observe the following tightening torques when tightening the lock nuts:

Type (GD/GS)	Nut size	Tightening torque [Nm]
040 till 063	M6	9
075 till 105	M8	17
125	M10	32
140 till 160	M12	62
190 till 240	M16	160
270	M20	315
300	M24	540
350 till 400	M27	800

Tab. 6-1 Tightening torques of bar-agturn lock nuts

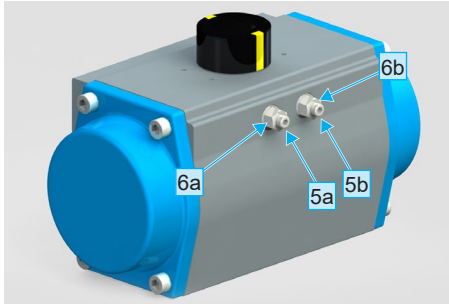

Fig. 6-3 Einstellung des Schwenkantriebs bar-agturn

- 6a** Lock nut
- 5a** Adjusting screw
- 6b** Lock nut
- 5b** Adjusting screw

### 6.2.1 Adjustment of swivel angle for mounting variants F/E

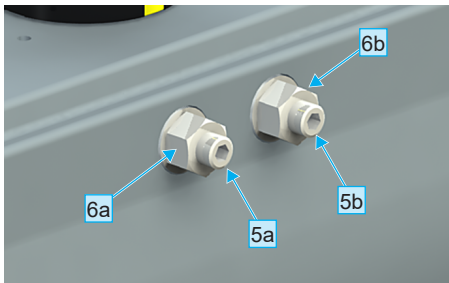

Fig. 6-4 Adjustment of the rotary actuator bar-agturn in details

#### Setting the closed valve position

1. If this is not already the case, allow the actuator to swing into the closed position.
  - Double-acting actuators: Supply compressed air to port 4, then bleed air.

2. Loosen the lock nut (6b) of the adjusting screw (5b).
3. Adjust the closed valve position with the adjusting screw (5b) and lock the adjusting screw with the lock nut.
4. Open and close the valve and check the setting. If necessary, repeat the points 1 to 4. If you also want to adjust the other end position, continue with point 5.

#### Setting the open valve position

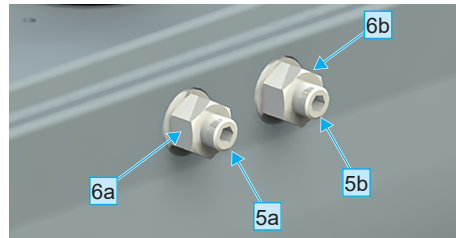

Fig. 6-5 Adjustment of the rotary actuator bar-agturn in details

1. If this is not already the case, allow the actuator to swing into the closed position and vent the actuator.
2. Loosen the lock nut (6a) of the left adjusting screw (5a) and make the adjustment with the adjusting screw. Lock the adjusting screw with the lock nut.
3. Open and close the valve and check both end positions.
4. If the opening angle is correct, return the actuator to the closed position and vent the actuator. If the setting needs to be corrected again, repeat points 5 to 8.

## 6.2.2 Adjustment of swivel angle for mounting variants G/H

### Setting the open valve position

1. If this is not already the case, allow the actuator to swing into the open position.
  - Double-acting actuators: Supply compressed air to port 4, then bleed air.
2. Loosen the lock nut (6b) of the right adjusting screw (5b).
3. Adjust the open valve position with the adjusting screw (5b) and lock the adjusting screw with the lock nut.
4. Close and open the valve and check both end positions. If necessary, repeat the points 1 to 4. If you also want to adjust the other end position, continue with point 5.

### Setting the closed valve position

1. If this is not already the case, allow the actuator to swing into the open position and vent the actuator.
2. Loosen the lock nut (6a) of the left adjusting screw (5a) and make the adjustment with the adjusting screw. Lock the adjusting screw with the lock nut.
3. Close and open the valve and check both end positions.
4. If the setting is correct, return the actuator to the open position and vent the actuator. If the setting needs to be corrected again, repeat points 5 to 8.

## 6.2.3 Adjustment of the swivel angle via the cover (actuators 120°/135°/180°)

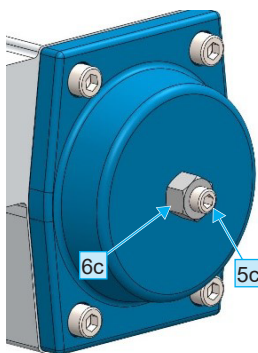

Fig. 6-6 Cover with adjusting screw for stroke limitation

- 6c** Lock nut  
**5c** Adjusting screw

### Mounting variants F/E

For mounting variants F/E, set the closed valve position as described in chapter 6.2.1.1.

The procedure for setting the open valve position is as follows:

1. If this is not already the case, allow the actuator to swing into the closed position and vent the actuator.
2. Loosen the lock nut (6c) of the adjusting screw in the cover (5c) and make the adjustment with the adjusting screw. Lock the adjusting screw with the lock nut.
3. Open and close the valve and check both end positions.

4. If the opening angle is correct, return the actuator to the closed position and vent the actuator. If the setting needs to be corrected again, repeat points 2 to 4.

### Mounting variants G/H

For mounting G/H, set the open valve position as described in chapter 6.2.1.

The procedure for setting the closed valve position is as follows:

1. If this is not already the case, allow the actuator to swing into the open position and vent the actuator.
2. Loosen the lock nuts (6c) of the adjusting screws in the cover (5c) and make the adjustment with the adjusting screw. Lock the adjusting screw with the lock nut.
3. Open and close the valve and check both end positions.
4. If the opening angle is correct, return the actuator to the open position and vent the actuator. If the setting needs to be corrected again, repeat points 2 to 4.

## 7. Maintenance and repair

The pneumatic rotary actuator bar-acturn works without maintenance.

In terms of operational safety, however, it is recommended to check them for function and to switch at least once a year but no later than after 100,000 switching cycles.

Do not use harsh detergents or abrasives to clean the housings. In principle, it is possible to repair the pneumatic rotary actuator by replacing the seal and wear parts sets.

### NOTE

We recommend that you have the repair carried out by the company bar GmbH! We will be pleased to offer you a corresponding servicing, maintenance or repair! Please contact the company bar GmbH for this.

## 8. Troubleshooting

### WARNING

#### Observe the safety instructions

There is danger to life if you do not observe safety instructions.

- When eliminating the faults, always observe the safety instructions from „Chapter 2. Safety“ .

### NOTE

Spare parts are to be ordered with all information on the type plate and the serial number. It is allowed to mount only original parts of bar GmbH.

## 9. Repair and spare parts

### 9.1 Type GD-032 (schematic diagram)

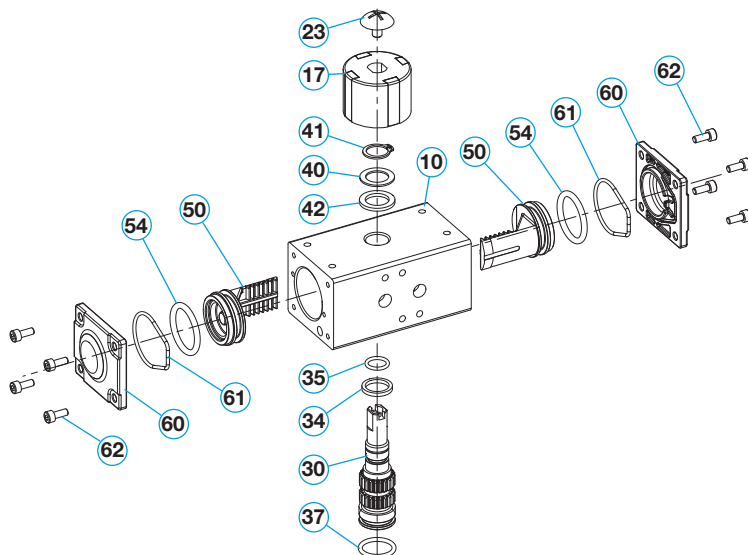

Fig. 9-1 Exploded-view drawing of all individual components of rotary actuator bar-acturn

10	Casing	35	Upper pinion seal	50	Piston
17	Position indicator	37	Lower pinion seal	54	Piston seal
23	Fixing screw to position indicator	40	Supporting ring	60	Cover
30	Pinion	41	Lock washer	61	Cover seal
34	Inner thrust washer	42	Outer thrust washer	62	Cover screws

Spare parts sets:

- Sealing set consists of: 35, 37, 54, 61
- Wear parts set consists of: 34, 42

<b>GD</b>	-	<b>050</b>	/	<b>090</b>	-	<b>08</b>	-	<b>Z..</b>	<b>A</b>
<b>GS</b>	-	<b>050</b>	/	<b>090</b>	-	<b>08</b>	-	<b>V22</b>	<b>F</b>
Operating way		Type		Swivel angle 90°		Number of springs		Pinion design	Installation variants
S = Single-acting D = Double-acting								V = Octagon with dimensions Z = Two-flats with dimensions	

Tab. 9-1 Order code bar-acturn (example)

## 9.2 Type GS-075 (schematic diagram)

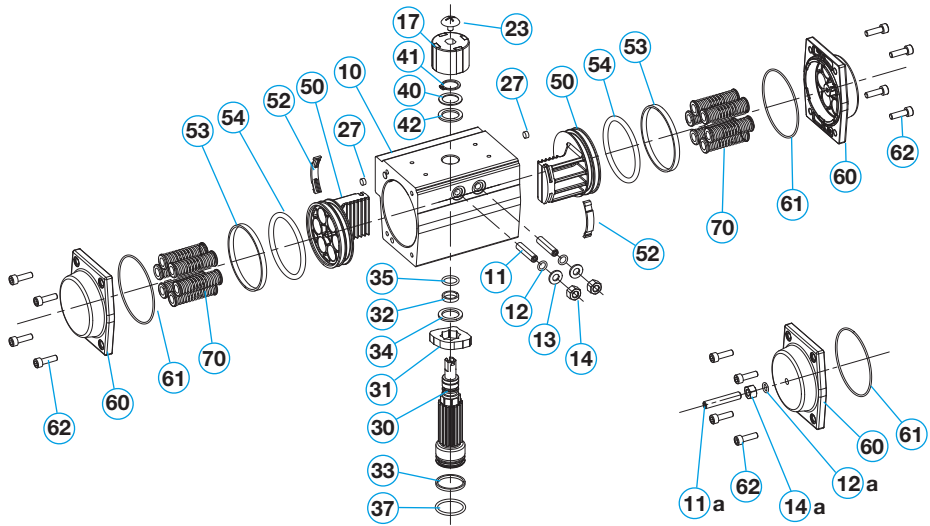

Exploded-view drawing of all individual components of rotary actuator bar-acturn

10	Casing	30	Pinion	50	Piston
11	Stop screw	31	Stop cam	52	Guiding shoe
12	Seal of stop screw	32	Upper pinion bearing	53	Guiding ring
13	Washer	33	Lower pinion bearing	54	Piston seal
14	Lock nut	34	Inner thrust washer	60	Cover
17	Position indicator	35	Upper pinion seal	61	Cover seal
23	Fixing screw to position indicator	37	Lower pinion seal	62	Cover screws
25	Ring nut	40	Supporting ring	70	Spring
26	Plastic washer	41	Lock washer		
27	Sealing plug channel 4	42	Outer thrust washer		

- Sealing set consists of: 12, 27, 35, 37, 54, 61
- Wear parts set consists of: 32, 33, 34, 42, 52, 53

<b>GD</b>	-	<b>360</b>	/	<b>090</b>	-	<b>Z...</b>	-	<b>A</b>
<b>GS</b>	-	<b>360</b>	/	<b>090</b>	-	<b>V22</b>	-	<b>F</b>
Operating way		Type		Swivel angle 90°		Number of springs		Pinion design
S = Single-acting								Installation variants
D = Double-acting								V = Octagon with dimensions
								Z = Two-flats with dimensions

Tab. 9-2 Order code bar-acturn (example)



## 10. Disassembly

### ⚠ WARNING

#### Installation works

There is a risk of injury if this product is not properly installed, disassembled and put into operation.

- Make sure the personnel has received the appropriate training.
- Observe the safety instructions in „Chapter 2. Safety“.

### 10.1 Disassembly of the rotary actuator

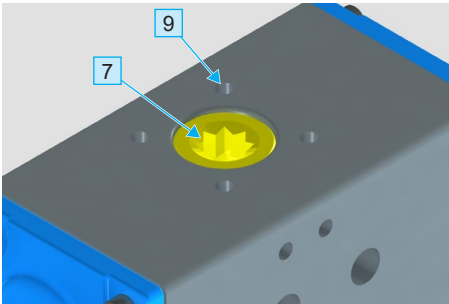

Fig. 10-1 Disassembly of the rotary actuator from the valve  
(view on actuator from below = valve interface)

- 7 Installation of the valve spindle / shaft adapter
- 9 Installation of connecting screws

To disassemble the valve, proceed as follows:

1. Loosen the connecting screws (9) between the valve and the rotary actuator.
2. Remove the rotary actuator from the valve spindle.
3. Remove any additional parts such as shaft adapter, reducer, mounting bridge and/or centering and store them carefully.

## 11. Disposal

- Proper disposal of the products is the responsibility of the customer. Dispose of the products after their use in accordance with the legal requirements regarding safety and environmental protection.
- The materials used in the products are steel, aluminum, brass and various plastics.

Dispose of lubricated parts separately according to local environmental regulations!

If you have any questions, please contact the company bar GmbH.

## 12. EU Declarations

### 12.1 Declaration of incorporation according to Directive 2006/42/EC

This is a representation of the contents of the declaration of incorporation. The signed declaration of incorporation can be found at [www.bar-gmbh.de](http://www.bar-gmbh.de)

We hereby declare that the incomplete machine described below - insofar as it is possible from the scope of delivery - complies with the basic requirements of the EC Machinery Directive listed below.

Commissioning of the incomplete machine is prohibited until the incomplete machine has been installed in a machine and it complies with the provisions of the EC Machinery Directive and the EC declaration of conformity in accordance with Annex II A is available.

We further declare that the specific technical documentation for this incomplete machine has been prepared in accordance with Annex VII, Part B and undertake to forward it to the competent national authorities through our documentation department upon a reasoned request.

Machine type	Pneumatic actuator
Machine designation	bar-agturn type GD/GS
Year of construction	From 2019
Relevant EC Directives	2006/42/EC
Fulfilled requirements of MD 2006/42/EC, Annex I Part 1	1.1.3, 1.1.5, 1.3.2, 1.3.4, 1,3,7, 1.3.9, 1.5.3, 1.5.4, 1.5.5, 1.5.7, 1.5.8, 1.7.3, 1.7.4
Applied harmonized standards	EN ISO 12100:2010
Applied national standards and technical specifications	None

Manufacturer and name of authorized representative responsible for the technical documentation:

bar pneumatische Steuerungssysteme GmbH  
 Auf der Hohl 1  
 53547 Dattenberg  
 Tel.: +49 (0)2644-9607-0  
 Fax: +49 (0)2644-960735  
 E-Mail: [bar-info@wattswater.com](mailto:bar-info@wattswater.com)

Place and date of issue: Dattenberg, 20.12.2018

Thomas Wild, Sales manager

## 12.2 ATEX Declaration of Conformity



bar 19.0002

Z500010\_00C

**A WATTS Brand**

Auf der Hohl 1 | 53547 Dattenberg | Germany | T: +49 (0)2644 9607-0 | F: +49 (0)2644 9607-35

### ATEX-Konformitätserklärung / ATEX-Declaration of Conformity

Name und Anschrift des Herstellers: **bar pneumatische Steuerungssysteme GmbH**  
*Name and address of the manufacturer:* **Auf der Hohl 1, 53547 Dattenberg / Germany**

Diese Erklärung bezieht sich nur auf das Produkt in dem Zustand, in dem es in den Verkehr gebracht wurde.  
 Die Erklärung verliert ihre Gültigkeit, wenn das Produkt ohne Rücksprache mit uns umgebaut oder verändert wird.  
*This declaration relates exclusively to the product in the state in which it was placed on the market.*  
*The declaration loses validity, if the product is modified without agreement of company bar.*

Hiermit erklären wir, dass das nachstehend beschriebene Produkt  
*Herewith we declare, that the following product*

Produktbezeichnung: **pneumatischer Stellantrieb**  
*Product denomination:* **pneumatic actuator**  
 Serien-/Typenbezeichnung / model/type: **bar-acturn Typ GD/GS**

nach den Anforderungen folgender Richtlinien hergestellt wurde  
*was manufactured according to the following directives:*

2014/34/EU ATEX-Richtlinie / ATEX - Directive (EU-Abl. L 96/309 vom 29.03.2014)

Die Einhaltung der in den technischen Daten und Sicherheitshinweisen beschriebenen Betriebsbedingungen ist sicherzustellen. Der anlagenseitige elektrische Potentialausgleich der Anbauteile ist zu prüfen und über die gesamte Einsatzzeit sicherzustellen.  
*Please take care about the technical data and the relevant warning and safety notices.*  
*Check the electrical equipotential bonding of all parts and ensure it during whole operating time.*

Gerätekennzeichnung / Designation:



II 2 G Ex h IIC T6...T3 Gb  
 II 2 D Ex h IIC T180°C Db

Max. Oberflächen-temperatur max. surface temperature	Max. zulässige Umgebungtemperatur max. permissible ambient temperature	Antriebsversion actuator version
T6 (85°C)	-40°C / -20°C < T <sub>a</sub> < +65°C	Tieftemperatur* oder Standard Deep Temperature* or Standard
T5 (100°C)	-40°C / -20°C < T <sub>a</sub> < +80°C	Tieftemperatur* oder Standard Deep Temperature* or Standard
T4 (135°C)	-20 < T <sub>a</sub> < +115°C	FKM-Version oder Hochtemperatur FKM-Version or High Temperature
T3 (200°C)	-20°C < T <sub>a</sub> < +160°C	Hochtemperatur High Temperature

Angewandte harmonisierte Normen: *Where appropriate harmonised Standards used:*

DIN EN ISO 80079-36:2016 Explosionsfähige Atmosphären – *Explosive atmospheres*  
 Teil 36: Nicht-elektrische Geräte für den Einsatz in explosionsfähigen Atmosphären – Grundlagen und Anforderungen  
*Part 36: Non-electrical equipment for explosive atmospheres – Basic method and requirements*  
 DIN EN ISO 80079-37:2016 Explosionsfähige Atmosphären – *Explosive atmospheres*  
 Teil 37: Nicht-elektrische Geräte für den Einsatz in explosionsfähigen Atmosphären – Schutz durch konstruktive Sicherheit  
 „c“ [...] *Part 37: Non-electrical equipment for explosive atmospheres – Non-electrical type of protection constructional safety "c"*

Dattenberg, 19.03.2020  
 Ort, Datum  
*Place, Date*

Wood, Nigel, Managing Director  
 Name, Vorname und Funktion des Unterzeichners  
*Surname, first name and function of signatory*

Unterschrift  
*Signature*



Deutsche Bank Neustadt Weinstraße • SWIFT DEUTDE5546 • IBAN DE35 5467 0095 0022 8114 00  
 Deutsche Bank Amsterdam • SWIFT DEUTNL2N • IBAN NL52 DEUT 0319 8666 53  
 HRB 10991 Amtsgericht Montabaur • Ust-Nr. DE 149 522 999  
 Geschäftsführer: Olivier Giverdon, Nigel Wood  
 bar-info@wattswater.com

bar-gmbh.de

## 13. Annex / Technical data

### Technical data

	<b>Standard design</b>	<b>Upon request</b>
Construction type	Pneumatic twin-piston rotary actuator  Type GD = double-acting Type GS = single-acting (with spring return)	
Design features	Rack-and-pinion principle with self-centering piston guide in the housing;  single-acting: with safety springs	
Mounting position	any	
Standards	Connection point actuator/signal device: acc. to: VDI/VDE 3845 (NAMUR)  Connection point actuator/control valve: acc. to NAMUR or VDI/VDE 3845  Connection point actuator/valve: four or eight internal threads in the actuator housing acc. to EN ISO 5211	Different mounting and connection dimensions are possible  Actuator pinion optionally with two-flats bore according to EN ISO 5211  or according to customer requirements
Materials	Housing: Al-alloy, hard anodised  Cover: Al-alloy, powder-coated  Piston/rack: Al-alloy  Pinion: corrosion-protected steel  Seals: NBR  Bearings: made of plastic with very good sliding properties  Screws: Stainless steel A2	Housing coating: powder-coated; PTFE  Cover coating: PTFE    Pinion: Stainless steel AISI 303; AISI 316  Seals: FKM
Ambient temperature	-20 °C to +80 °C	Low temperature design: -40 °C to +80 °C  High temperature design: -20 °C to +160 °C
Nominal swivel angle	double- and single-acting: 90°  Nominal swivel angle can be adjusted as standard from + 5° to -5° in both end positions	Another swivel angles upon request
Torque	2 Nm to 13.040 Nm	
Control pressure	2 to 8 bar	
Control medium/quality	Filtered air with regard to residual oil content, dust and water minimum according to  DIN ISO 8573-1: 2010 [7:-:4]	Upon request also can be operated with other non-aggressive, gaseous or liquid media

**Tab. 13-1 Technical data**

Dimensional drawings for bar-agturn type GD-032

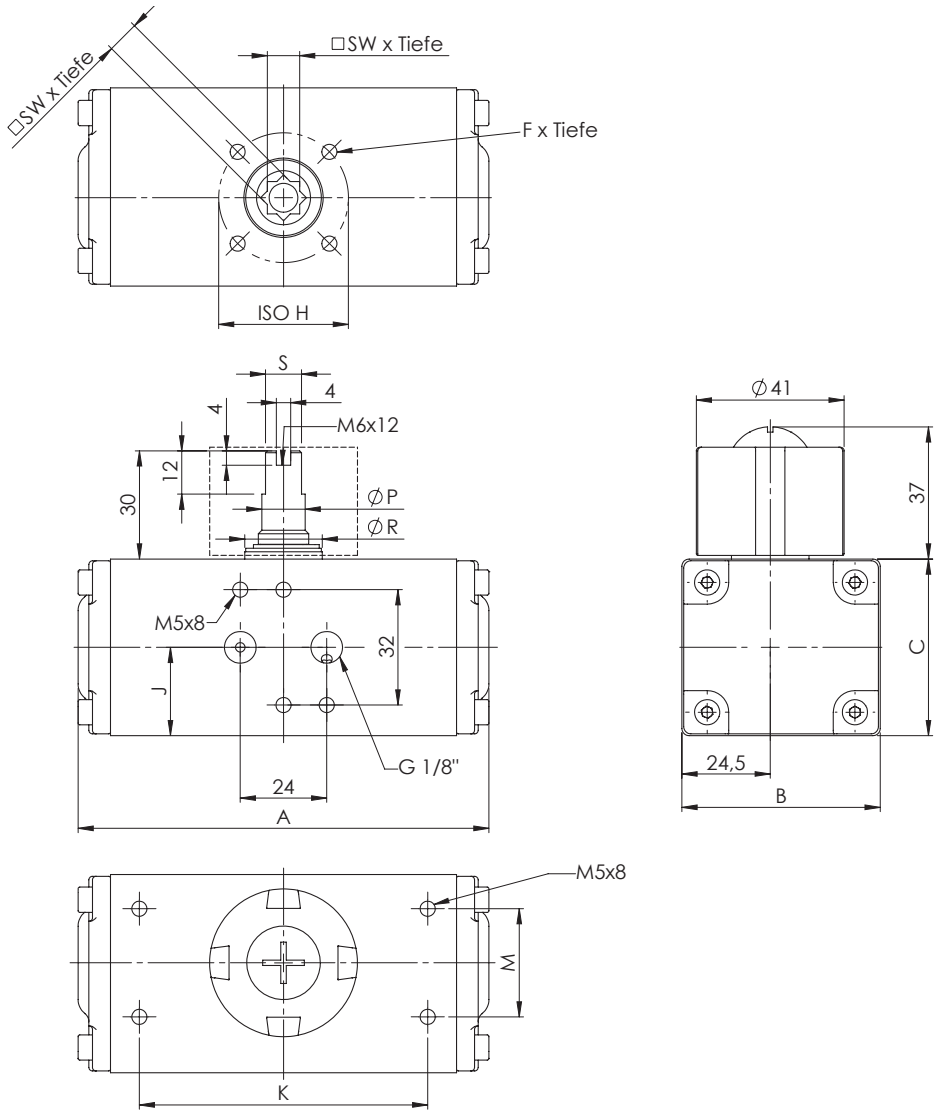
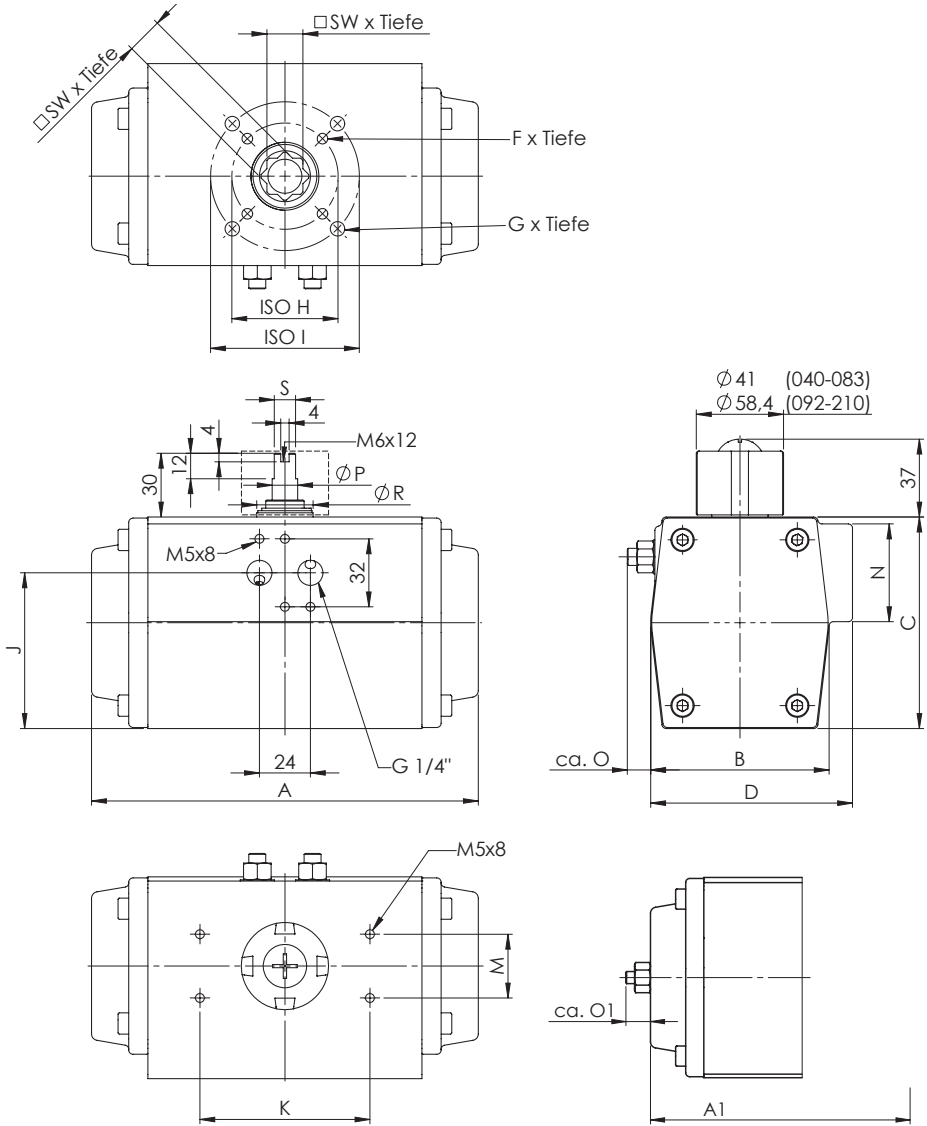

Fig. 13-1 Dimensional drawing bar-agturn type GD-032

**Dimensional drawings for bar-agtturn type GD/GS-040 till 210**



**Fig. 13-2 Dimensional drawing bar-agtturn type GD/GS-040 till 210**

Dimensional drawings for bar-agturn type GD/GS-240 till 270

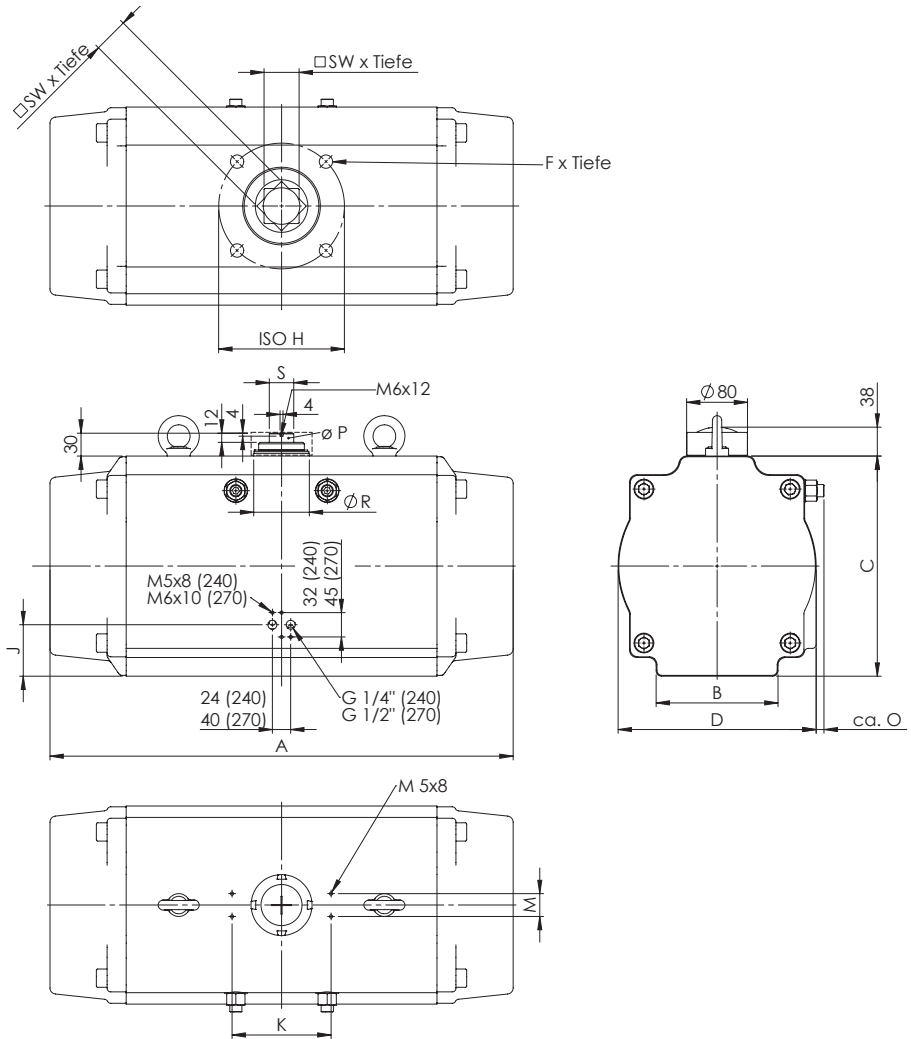

Fig. 13-3 Dimensional drawings for bar-agturn type GD/GS-240 till 270

Dimensional drawings for bar-agturn type GD/GS-300 till 400

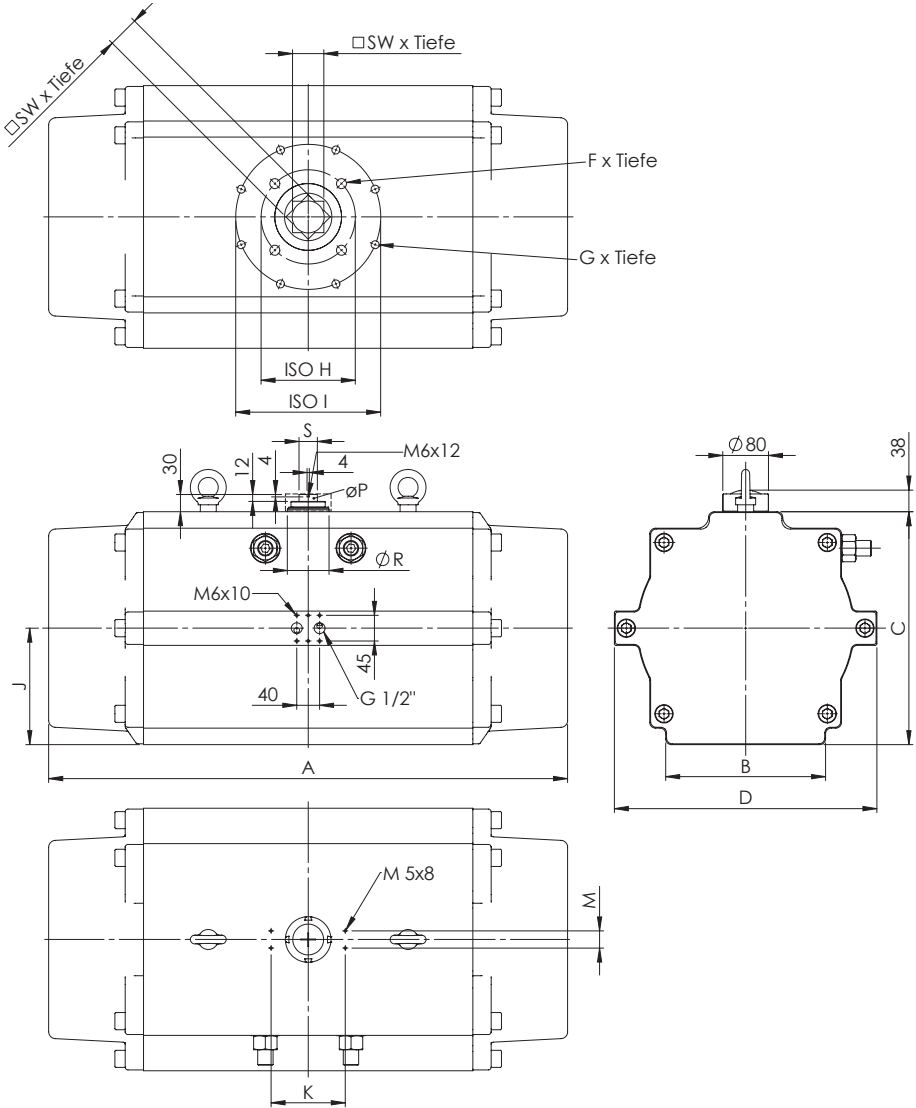

Fig. 13-4 Dimensional drawings for bar-agturn type GD/GS-300 till 400



## Measurement chart

Type GD/GS	A	A1	B	C	D	E	F x depth	G x depth	ISO H	ISO I
<b>32</b>	114		55	49		1/8"	M5x8		ø36/F03	
<b>40</b>	120		60.5	60		1/4"	M5x8	M6x9	ø36/F03	ø50/F05
<b>52</b>	147	210	60	72	74.5	1/4"	M5x8	M6x9	ø36/F03	ø50/F05
<b>63</b>	165	241	72	88	83	1/4"	M6x10	M8x13	ø50/F05	ø70/F07
<b>75</b>	182	258	84	99.5	95	1/4"	M6x10	M8x13	ø50/F05	ø70/F07
<b>83</b>	208	302	92	109	103	1/4"	M6x10	M8x13	ø50/F05	ø70/F07
<b>92</b>	262	375	102	116.5	109.5	1/4"	M6x10	M8x13	ø50/F05	ø70/F07
<b>105</b>	270	397	115	133	124.5	1/4"	M8x13	M10x16	ø70/F07	ø102/F10
<b>125</b>	301	443	135	155	142	1/4"	M8x13	M10x16	ø70/F07	ø102/F10
<b>140</b>	395	585	152	172		1/4"	M10x16	M12x19	ø102/F10	ø125/F12
<b>160</b>	454	675	174	197		1/4"	M10x16	M12x19	ø102/F10	ø125/F12
<b>190</b>	528	781	206	230		1/4"	M16x24		ø140/F14	
<b>210</b>	536	789	226	255		1/4"	M16x24		ø140/F14	
<b>240</b>	608		160	289	260	1/4"	M20x25		ø165/F16	
<b>270</b>	721		160	328	294	1/2"	M20x25		ø165/F16	
<b>300</b>	769		210	348	406	1/2"	M20x25		ø165/F16	
<b>350</b>	909		280	408	460	1/2"	M20x25	M16x25	ø165/F16	ø254/F25
<b>400</b>	925		300	480	516	1/2"	M20x25	M16x25	ø165/F16	ø254/F25

Tab. 13-2 Measurement chart for bar-agturn type GD/GS-032 till 400, size A till ISO I

## Measurement chart

Type GD/GS	J	K	M	N	O	O1	P	R	S	SW x depth
<b>32</b>	24.5	80	30				ø12	ø21,5	10	9x11
<b>40</b>	24	80	30		15		ø12	ø21,5	10	11x14
<b>52</b>	48	80	30	46	9	16	ø12	ø21,5	10	11x14
<b>63</b>	61	80	30	46	12	14	ø12	ø26,5	10	14x18
<b>75</b>	73.3	80	30	46	11	14	ø12	ø26,5	10	17x21
<b>83</b>	80	80	30	46	12	16	ø12	ø26,5	10	17x21
<b>92</b>	91	80	30	46	9	22	ø18	ø35	14	17x21
<b>105</b>	99.5	80	30	46	7.5	16	ø18	ø35	14	22x26
<b>125</b>	127	80	30	46	8.5	23	ø28	ø46	20	22x26
<b>140</b>	138	80	30	75	7	16	ø28	ø51	20	27x31
<b>160</b>	159.5	80	30	84	6	15	ø28	ø51	20	27x31
<b>190</b>	188	130	30	100	8.5	38	ø44	ø61	32	36x40
<b>210</b>	205.5	130	30	115	10.5	35	ø44	ø73	32	36x40
<b>240</b>	67.5	130	30		10.5		ø44	ø73	32	46x50
<b>270</b>	79	130	30		13.5		ø44	ø73	32	46x50
<b>300</b>	174	130	30				ø44	ø73	32	46x60
<b>350</b>	204	130	30				ø44	ø73	32	55x60
<b>400</b>	240	130	30				ø44	ø73	32	55x60

Tab. 13-3 Measurement chart for bar-agturn type GD/GS-032 till 400, size J till SW x depth

## Weight and volume

Type GD/GS	Weight	Volume/ double stroke	Weight*	Volume/ double stroke
	GD [kg]	GD [L]	GS [kg]	GS [L]
<b>032</b>	0.73	0.09	-	-
<b>040</b>	0.9	0.19	-	-
<b>052</b>	1.3	0.28	1.43	0.12
<b>052/180</b>	1.9	0.47	-	-
<b>063</b>	2.0	0.44	2.17	0.21
<b>063/180</b>	2.9	0.79	-	-
<b>075</b>	2.55	0.64	2.81	0.30
<b>075/180</b>	3.7	1.13	-	-
<b>083</b>	3.25	0.9	3.67	0.43
<b>083/180</b>	4.9	1.6	-	-
<b>092</b>	5.24	1.37	6.01	0.64
<b>092/180</b>	6.6	2.45	-	-
<b>105</b>	6.06	1.83	6.9	0.95
<b>105/180</b>	9	3.48	-	-
<b>125</b>	10.00	3.0	11.38	1.6
<b>125/180</b>	13.0	5.65	-	-
<b>140</b>	14.02	4.7	16.42	2.5
<b>140/180</b>	21	9.16	-	-
<b>160</b>	24.52	6.9	28.32	3.7
<b>160/180</b>	31	13.69	-	-
<b>190</b>	32.4	11.3	39.4	5.9
<b>190/180</b>	46	22.33	-	-
<b>210</b>	39.8	15.0	49.3	7.5
<b>210/180</b>	54	28.53	-	-
<b>240</b>	57.0	20.0	70.0	11.0
<b>270</b>	78.7	31.0	100.3	17.0
<b>300</b>	121.7	53.5	149.12	23.8
<b>350</b>	210.2	81.4	259.3	35.1
<b>400</b>	280	108.6	325	52.6

\* Weight with maximum number of springs

Tab. 13-4 Weight and volume of the rotary actuators

The bar products are comprehensively tested. The company bar therefore only guarantees the replacement or - at its sole discretion - the free repair of those components of the delivered products which, in the opinion of bar, have demonstrable manufacturing defects. Warranty claims due to defects or defects of title can be asserted within one (1) year from delivery/transfer of risk. Excluded from the warranty are damages due to normal product use or friction as well as damages due to changes or unauthorized repairs to the products for which bar rejects any claim for damages (direct or indirect). (Please refer to our website for detailed information.) All deliveries are subject to the General Conditions of Sale which can be found at [www.bar-gmbh.de](http://www.bar-gmbh.de).

---

The descriptions and images contained in this product data sheet are for informational purposes only and are not guaranteed. bar GmbH reserves the right to make technical and constructive changes to its products without prior notice.

Warranty: All purchases and sales contracts expressly require the Purchaser to accept the General Terms and Conditions of Sale and Delivery which can be found on [www.bar-gmbh.de/agb](http://www.bar-gmbh.de/agb). bar GmbH hereby objects to any deviating or additional condition to the General Terms and Conditions of Sale and Delivery which has been communicated to the Purchaser in any form without the written consent of a representative of bar GmbH.

---

**bar**  
A **WATTS** Brand

---

**bar pneumatische Steuerungssysteme GmbH**  
Auf der Hohl 1 • 53547 Dattenberg • Germany  
Tel. +49 (0)2644 96070 • Fax +49 (0)2644 960735  
[bar-info@wattswater.com](mailto:bar-info@wattswater.com) • [www.bar-gmbh.de](http://www.bar-gmbh.de)