

actubar[®]

Pneumatic rotary actuator

Translation of the operating manual



Table of Contents

1.	General information	5
1.1	Reference documents.....	5
1.2	Validity of the operating manual.....	5
1.3	Notes to operating manual	5
1.3.1	Signal words and symbols	5
1.3.2	Explanation of the structure of the safety instructions.....	7
1.3.3	Descriptions in figures.....	7
1.4	Responsibility of the operating company.....	7
2.	Safety	8
2.1	General Safety Instructions	8
2.2	Intended use.....	8
2.3	Reasonable foreseeable ure.....	8
2.4	Organizational measures	8
2.4.1	Modification or changes to the rotary actuator.....	8
2.4.2	Replacement of defective parts.....	8
2.5	Protective equipment.....	8
2.6	Personnel qualification	9
2.7	Dangers when handling the pneumatic rotary actuator.....	11
2.7.1	Dangers during assembly, maintenance and disassembly	11
2.7.2	Dangers during functional checks, commissioning and operation.....	14
2.7.3	Dangers when used in explosion-protected areas	15
3.	Product description	16
3.1	Overview of different models	16
3.1.1	Product overview.....	16
3.2	Type plate.....	18
3.3	Additional marking for the actuator	18
3.4	Product and function description.....	19

3.5	Operating and display elements	20
3.6	Accessories	21
4.	Transport and storage	21
4.1	Scope of delivery	21
4.1.1	Incoming goods inspection.....	21
4.2	Transport, packaging and storage.....	22
5.	Installation	23
5.1	Installation conditions.....	23
5.2	Before installation	23
5.3	Installation of the valve	24
5.4	Installation of the pneumatic connection.....	25
5.4.1	Installation of the vacotrol interface	26
5.5	Pressure test of the pipe section	26
6.	Commissioning and operation	27
6.1	General information for commissioning of different variants.....	27
6.2	Setting the end positions.....	27
6.2.1	End position setting Type AD/AS-002	29
6.2.2	End position setting Type AD/AS-004 till 1200	30
7.	Maintenance and repair	32
8.	Troubleshooting	32
9.	Repair and spare parts	33
9.1	Type AD-001 (schematic diagram).....	33
9.2	Type AD/AS-002 (schematic diagram).....	34
9.3	Type AD/AS-004 till 230 (schematic diagram)	35
9.4	Type AD/AS-360 till 1200 (schematic diagram).....	36

10. Disassembly	37
10.1 Disassembly of the rotary actuator	37
11. Disposal	37
12. EU Declarations	38
12.1 Declaration of incorporation according to Directive 2006/42/EG.....	38
12.2 ATEX-Declaration of Conformity	39
13. Annex / Technical data	40
13.1 Technical data.....	40
13.2 Dimensional drawings for actubar type AD-001.....	41
13.3 Dimensional drawings for actubar type AD/AS-002.....	41
13.4 Dimensional drawings for actubar type AD/AS-004 and 006	42
13.5 Dimensional drawings for actubar type AD/AS-008 till 230.....	43
13.6 Dimensional drawings for actubar type AD/AS-360 till 1200.....	44
13.7 Measurement chart.....	45
13.8 Weight and volume	47

1. General information

This operating manual is a part of the product. The operating manual must be kept for the entire life of the product and must be passed on to each subsequent owner of the product.

The operating manual must always be available at the place of operation.

1.1 Reference documents

This manual, the data mentioned and design data sheets, additional assembly and maintenance instructions as well as further information – also in other language versions, can be obtained from:

bar pneumatische
Steuerungssysteme GmbH

Auf der Hohl 1
53547 Dattenberg

Tel.: +49 (0)2644-9607-0
Fax: +49 (0)2644-960735

Email: bar-info@wattswater.com
www.bar-gmbh.de

1.2 Validity of the operating manual

This operating manual is valid for the following actubar® rotary actuators starting from year of construction 2019:

- Type AD-001
- Type AD/AS-002
- Type AD/AS-004 and 006
- Type AD/AS-008 till 230
- Type AD/AS-360 till 1200

1.3 Notes to operating manual

The safety and hazard statements in the document are intended for your protection, the protection of third parties and the protection of the product. The instructions must therefore be observed.

1.3.1 Signal words and symbols

DANGER

... indicates a hazard that, if not avoided, will result in death or serious injury.

WARNING

...indicates a hazard that, if not avoided, could result in death or serious injury.

CAUTION

...indicates a hazard which, if not avoided, could result in minor or moderate injury.

NOTE

...indicates important information (e.g. Material damage) but not hazards.



Electric voltage!

The text passages marked with this symbol inform you about dangerous situations with danger to life and health of persons due to electrical voltage.



Corrosive substances!

The text passages marked with this symbol inform you about dangerous situations caused by corrosive substances.



Hot surface!

The text passages marked with this symbol inform you about dangerous situations with a risk of burns due to hot surfaces.



Cold surface!

The text passages marked with this symbol inform you about dangerous situations with a risk due to cold surfaces.



Suspended load!

The text passages marked with this symbol inform you about dangerous situations with a risks due to suspended load.



Hand injuries!

The text passages marked with this symbol inform you about dangerous situations resulting in hand injuries caused by bruising or punching. The activities described in the relevant text passage must be performed with the utmost care to avoid dangerous situations and resulting injuries such as loss of limbs.



Use head protection!

Notes with this symbol indicate that a head protection must be worn.



Use protective clothing!

Notes with this symbol indicate that a protective clothing must be worn.



Use hand protection!

Notes with this symbol indicate that a hand protection must be worn.

1.3.2 Explanation of the structure of the safety instructions

A safety instruction is initiated with a signal word describing the severity of the danger („Chapter 1.3.1 Signal words and symbols“)

WARNING

Type or source of danger (possibly with warning signs according to DIN EN ISO 7010)

Consequences in case of not following the instruction

- Avoidance of danger

1.3.3 Descriptions in figures

The figures in this operating manual are intended to help you understand the facts and procedures.

The descriptions in the figures are exemplary and may differ slightly from the actual appearance of your product.

1.4 Responsibility of the operating company

- The installation, electrical and pneumatic connection as well as the commissioning of the product may only be carried out by qualified personnel in accordance with the instructions described in this operating manual.
- The product may only be operated and maintained by personnel of the legal minimum age and the corresponding personnel qualification.
- This operating manual is an integral part of the product and must be available to the personnel at all times. This operating manual must be read and understood before the first commissioning.
- The operating and technical personnel must be instructed about safety devices of the product as well as safe working methods.
- The product may only be operated in perfect condition. No safety devices may be removed or disconnected.

2. Safety

2.1 General Safety Instructions

Personnel assigned to work on the rotary actuator must read the operating instructions before starting work and, in particular, understand the chapter “Safety” before starting work. This is particularly valid for personnel working only occasionally on the rotary actuator.

2.2 Intended use

- The product is designed for use in process engineering systems.
- The product is used for the automatic actuation of industrial valves continuously moving between the end positions by means of compressed air. Operation with other gases or liquids must be approved in writing by the manufacturer.
- The product is suitable for the automation of valves in order to shut-off liquids and gases in pipelines and containers.
- The operating values, limit values and setting data specified in the operating instructions and the corresponding data sheet must not be altered without the written permission of the manufacturer.
- Intended use also includes the observance of these operating instructions.

2.3 Reasonable foreseeable use

Any use other than that described in „Chapter 2.2 Intended use“ and any use not approved by the manufacturer is considered as unintended!

2.4 Organizational measures

2.4.1 Modification or changes to the rotary actuator

The unauthorized modification and/or changes to the product is prohibited for safety and licensing reasons (CE). Changes to the product may only be made after consultation and written approval from the manufacturer.

2.4.2 Replacement of defective parts

Replace parts of the quarter-turn actuator that are not in perfect condition immediately with original spare parts.

Please note that only original spare and wear parts of bar GmbH are to be used.

In the case of usage of the third-party parts, it is not ensured that they are designed and manufactured to suit the requirements.

2.5 Protective equipment

If necessary, the protective equipment shall be used. Keep your hair and clothing away from moving parts. If necessary, wear a hairnet and do not wear jewelry such as necklaces and rings!



Use head protection!

Wear suitable head protection during transport.



Use protective clothing!

Wear suitable protective clothing during commissioning, maintenance and troubleshooting.



Use hand protection!

Wear suitable hand protection during transport, commissioning, maintenance and troubleshooting.

- Instructed persons must operate the rotary actuator and be able to detect possible damage and dangers on the rotary actuator.
- Instructed persons with technical training must also be aware of the dangers of handling pressurized equipment, hot and cold surfaces, harmful and hazardous materials and the process of installing and removing the valves in a process line, the specific and potential risks of the process and the most important safety regulations.
- Trained electricians must read and understand electrical circuit diagrams, commission, put electric machines into operation, service and maintain them, wire switch and control cabinets, install control software, ensure the functionality of electrical components and identify potential hazards in handling electrical and electronic systems.
- Trained pneumatic specialists must read and understand pneumatic circuit diagrams, put pneumatic systems into operation, service and maintain them, disconnect and connect pneumatic hoses, ensure the proper functioning of pneumatic components, assess the work performed on the pneumatic system and identify potential hazards.

2.6 Personnel qualification

Only trained or instructed personnel who has known and understood the operating instructions as well as the possible dangers of the rotary actuator is allowed to work with the rotary actuator. The responsibility of the personnel for operation, maintenance and repair must be clearly defined by the operator.

Personnel to be trained, instructed or undergoing training may work on the rotary actuator only under the constant supervision of an experienced person.

The individual activities on the rotary actuator require different personnel qualifications which are listed in the following table. The different qualifications are characterized by the following skills and knowledge:

Read this table as follows:

“The electrical installation requires the qualification of a qualified electrician.”

Activities	Instructed persons	Instructed persons with technical training	Electricians	Pneumatic specialists
Installation		X		
Electrical installation			X	
Pneumatic installation				X
Setting and equipping		X		
Commissioning		X		
Troubleshooting	X			
Cleaning	X			
Troubleshooting, repair and maintenance of mechanics		X		
Troubleshooting, repair and maintenance of electrics			X	
Troubleshooting, repair and maintenance of pneumatics				X
Functional checks		X		
Shutdown	X		X	
Transport	X			
Disposal	X			

Tab. 2-1 Overview of the required personnel qualifications

2.7 Dangers when handling the pneumatic rotary actuator

This product of bar GmbH is built according to the state of the art and the recognized safety rules. Nevertheless, there remains a residual risk and may cause dangers to the life and limb of the user or third parties or impairments of the product and other material assets in use, if:

- the product is not used as intended,
- the product is operated or repaired by untrained personnel,
- the product is improperly changed or modified and/or
- the safety instructions are not observed.

Eliminate faults that may affect safety.

2.7.1 Dangers during assembly, maintenance and disassembly

WARNING



Electric voltage!

There is danger to life when working on electrical components.

- The electrical connections may be performed only by qualified electricians.
- When working on the components, have the voltage released by a qualified electrician and secured against being switched on again.
- Let a qualified electrician check that no current is present.

WARNING



Corrosive substances!

Depending on the type of medium, there may be danger to life when in contact with the medium.

- Check the properties of the medium.
- Protect yourself and your environment from harmful or toxic substances.
- Follow the safety instructions in the manufacturer's safety data sheets.
- Make sure that no medium can get into the pipeline, valves during assembly work.
- Make sure that personnel working with the valves and installing or repairing the valves have received appropriate training.

WARNING



Very cold and hot surfaces!

The body of the valve can become very cold or very hot during operation.



- Wear protective gloves and protective clothing to protect against frostbite or burns.
- Make sure that personnel working with the valves and installing or repairing the valves have received appropriate training

⚠ WARNING



Danger of crushing hands and other body parts!

There is a risk of injury during assembly/disassembly by movements of the ball. The shut-off body (e.g. ball or disc) of the valve works as a separating element. It makes no difference whether a rotary actuator is mounted or not. The position of the ball may change during transport or handling of the valve.

- Keep hands and fingers away with the compressed air supply connected.
- Always disconnect the compressed air supply from the rotary actuator before carrying out maintenance and repair work on the valve and when installing and removing the ball valve from the pipeline.
- Pay attention to movements of the ball.
- Keep hands, other body parts, tools and other objects out of the swivel range of the ball. Do not leave any foreign objects inside the pipeline.
- Perform works carefully when assembling, disassembling and sampling

⚠ WARNING

**Flying parts!
Splashing medium!**

There is a risk of injury when the valve is removed under pressure or with present medium. The disassembly or removal of a pressurised valve causes an uncontrolled pressure drop.

- Do not disassemble or remove the valve from the pipeline as long as the valve is pressurized.
- Always isolate the respective valve in the piping system.
- Depressurise the valve and remove the medium before working on the valve and the rotary actuator.

⚠ WARNING

Ejected parts!

If the end stops are misaligned under pressure, the vacotrol interface or the rotary actuator itself is opened, there is a risk of parts being ejected!

- Always disconnect the compressed air supply before maintenance, disassembly and repair!
- Never set the mechanical end positions on the actuator as long as there is pressure on connection 2 or 4.
- Never dismount the threaded pins of the vacotrol interface under pressure.
- Make sure the pinion of the rotary actuator is moving in the correct direction.

⚠ WARNING

Welding works!

Welding and flying sparks can cause fires.

- Make sure that the prescribed safety precautions are taken before carrying out welding works.
- Inform the relevant employees such as security officer, shift leader, company fire brigade.
- Apply for a written welding permit.
- Provide fire extinguishers.

⚠ CAUTION

Hand injuries!

When mounting the rotary actuator on the valve spindle, the rotary actuator is pushed to the connection point/flange of the valve.

When disassembling the rotary actuator or removing the rotary actuator from the valve spindle, the parts can slip down.

There is danger of crushing the hands!

- Carefully pull off the rotary actuator.
- Keep fingers and hands away from the connection point

⚠ WARNING

Uncontrolled start-ups

There is a risk of injury if pneumatic rotary actuators create a very high torque during actuation or by spring force.

- Secure the rotary actuator against any unintentional start-up or unexpected spinning.
- Work on the pneumatic rotary actuators in a prudent way.
- In case of single-acting rotary actuators (type GS), make sure that the rotary actuator is in the home position (relaxed springs) when disassembling.

NOTE

Material damage to valve spindle!

Material damage can occur if you use built-on rotary actuators as levers.

- Do not use built-on actuators as levers as they could damage the actuator and the valve.

2.7.2 Dangers during functional checks, commissioning and operation

WARNING

Bursting parts!

Escaping media!

There is danger to life if the maximum permissible pressure and temperature ranges of the valve are insufficient for the operating conditions of the system. There is a risk of injury and the risk of material damage by wrongly selected materials.

In addition, there is a risk of damage to the piping system.

- Only use the valves that are designed for the operating conditions.
- Make sure that the selected materials of the parts of the valve coming in contact with the medium are suitable for the media used.

WARNING



Escaping medium!

There is a risk of injury from escaping medium as a result of leaks (scalding, hazardous substances).



- Protect yourself from thermal or chemical burns.
- Leave the danger area in case of leakage and keep third persons out of the danger zone. Use appropriate barriers or name supervisors.

WARNING



Danger of being pulled in,

Danger of crushing and locking

Danger due to moving parts of the machine/ valve which can be accessed through assembly, disassembly, removable covers at openings for functional checks, sampling, etc. and through automatically operated valves.

- Keep hands and fingers away with the compressed air supply connected.
- Please note that single-acting rotary actuators can move the valve to the “open” or “closed” position when closing or disconnecting the compressed air supply.
- Perform works carefully when commissioning, making functional checks and sampling.

WARNING



Risk of burns!

Devices and system components can become very hot during operation.

- Wear protective gloves and protective clothing to protect against burns.
- At operating temperatures > 65°C a short contact (approx. 1s) of the skin with the surface of the machine/valve may cause burns (DIN EN ISO 13732-1).

- At operating temperatures = 60 °C a long contact (approx. 3s) of the skin with the surface of the machine/valve may cause burns (DIN EN ISO 13732-1).
- At operating temperatures 55 °C–60 °C a long contact (approx. 3s to 10s) of the skin with the surface of the machine/valve may cause burns (DIN EN ISO 13732-1).

CAUTION

Self-loosening components!

Components and fasteners may become loose if not properly installed.

- Observe the information on tightening torques in this operating manual.
- Check the tightening torque of screw connections and tighten with the torque wrench, if necessary.

CAUTION

Noise!

When venting the pneumatic rotary actuator, noise can be hazardous to health.

- Use silencer at vent port or take other personal protection measures.

2.7.3 Dangers when used in explosion-protected areas

DANGER

Danger of explosion

An explosion can occur if the following protective measures are not observed:

- Establish an internal electrically conductive equipotential bonding between the rotary actuator and all metal mounting parts and the pipeline.
- Protect the surfaces against inadmissibly high temperatures due to solar radiation. Shading covers can possibly be required.
- When selecting the pneumatic valves and the end position feedbacks, pay attention to the combination with Ex-approved products.
- Avoid sparking when using the tool.
- Avoid dust accumulation.
- Do not install rotary actuators in pitlike cavities if there is a predictable dust accumulation.
- Do not carry out leak detection with ultrasonic transmitters.

3. Product description

3.1 Overview of different models

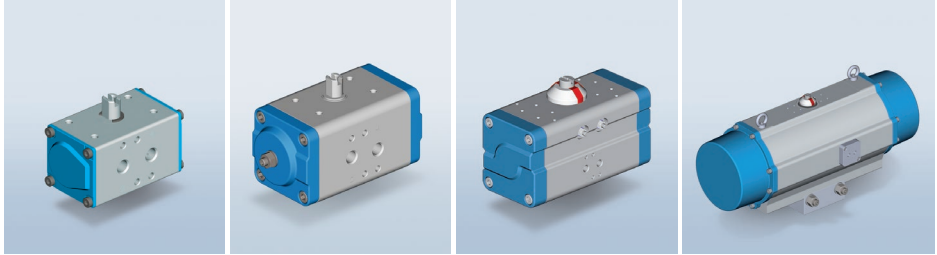

Fig. 3-1 Product variants actubar (AD-001, AD/AS-002, AD/AS-004 till 230, AD/AS-360 till 1200)

3.1.1 Product overview

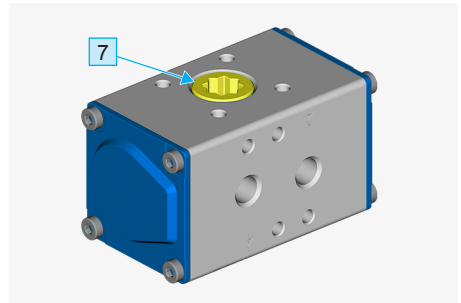
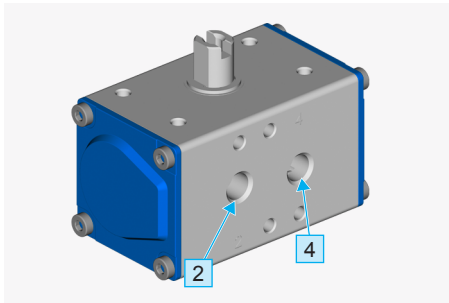

Fig. 3-2 actubar AD-001 overview of components (left: top view, right: bottom view)

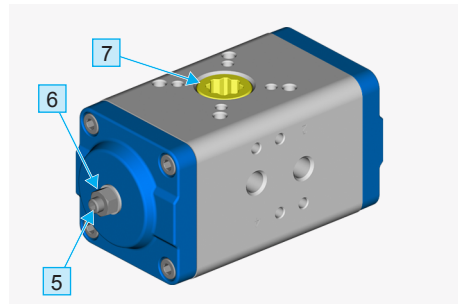
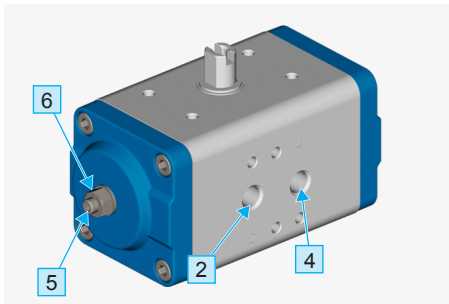

Fig. 3-3 actubar AD/AS-002 overview of components (left: top view, right: bottom view)

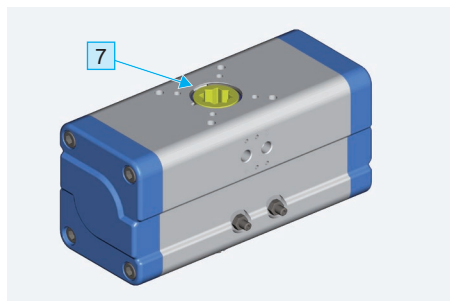
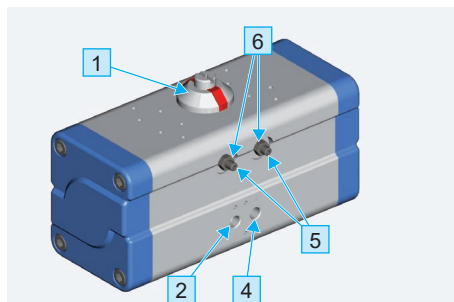

Fig. 3-4 actubar AD/AS-004 till 230 overview of components (left: top view, right: bottom view)

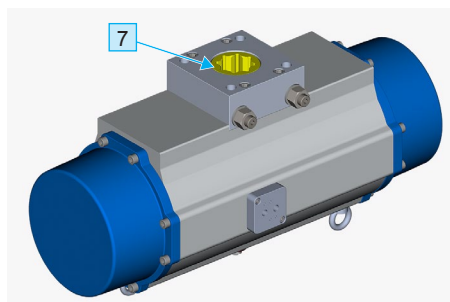
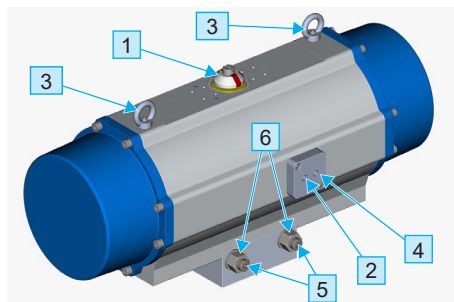

Fig. 3-5 actubar AD/AS-360 till 1200 overview of components (left: top view, right: bottom view)

Legend

- | | |
|---|---|
| <ol style="list-style-type: none"> 1. Position indicator and interface to the end position feedback as well as position controllers according to VDI/VDE 3845 (Namur) 2. Pneumatic interface connection of the actuator according to VDI/VDE 3845 (Namur) 3. Ring nut from AD/AS-160 | <ol style="list-style-type: none"> 4. Pneumatic interface connection of the actuator according to VDI/VDE 3845 (Namur) 5. Adjusting screws 6. Lock nuts of the adjusting screws 7. Valve interface according to EN ISO 5211 |
|---|---|

3.2 Type plate

The following figures and the legend contain examples of different versions of a pneumatic rotary actuator.



Fig. 3-6 Type plate double-acting and single-acting

Legend

60001351/60003041	bar article number
AD-011/090-00-V17-F	Article/order designation (see data sheet)
Md=11,0Nm/bar	Torque per 1 bar of control pressure
10 springs	Number of safety springs for single-acting actuators
Pmax=8bar	Permis. max. control pressure for the pneum. rotary actuator
Last line	ATEX marking and date of manufacture (year of construction)

3.3 Additional marking for the actuator



- 1 High temperature design up to +160 °C
- 2 Low temperature design up to -40 °C
- 3 Seals made of FKM

Fig. 3-7 Additional marking for the actuator no. 1 till 3

3.4 Product and function description

The pneumatic rotary actuator actubar is actuated exclusively with compressed air or other suitable control media via control valves. The swivel angle range is 90° and can be set as standard in both end positions (0° and 90°) from +5° to -10°.

The pneumatic rotary actuator is delivered as required in a double- and single-acting function (with safety springs which return the rotary actuator to the basic position). The respective valve position is indexed via the standard optical position indicator (see Fig. 3-11 and Fig. 3-12). The end position feedback device can be ordered as an accessory

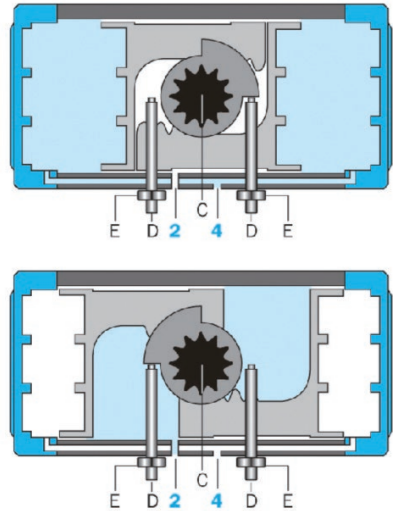

Fig. 3-8 Rotary actuator actubar „double-acting“ function

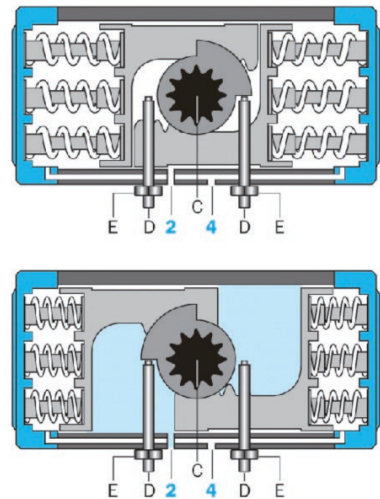

Fig. 3-9 Rotary actuator actubar „single-acting“ function

3.5 Operating and display elements

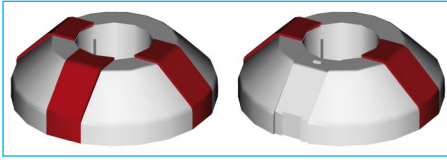

Fig. 3-10 Operating and display elements of the rotary actuator actubar
Position indicator with red clips

The positions of the valve are indicated by an optical position indicator mounted on the rotary actuator. The red clips are to be allocated according to the type of valve and, if necessary, removed. E.g.:

- 2-way valve corresponds to 2 clips of I-shape
- 3-way valve with T-bore corresponds to 3 clips of T-shape
- 3-way valve with L-bore corresponds to 2 clips of L-shape

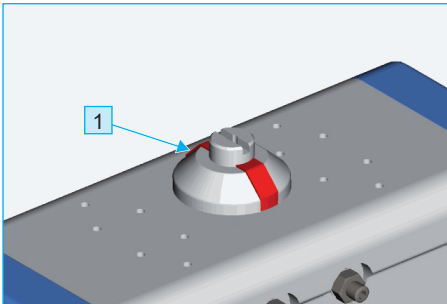

Fig. 3-11 Operating and display elements of the rotary actuator actubar
Longitudinal design = closed position
Transverse design = open position

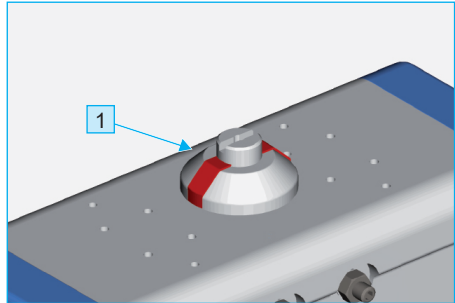

Fig. 3-12 Operating and display elements of the rotary actuator actubar
Longitudinal design = open position
Transverse design = closed position

In case of **longitudinal design** the position indicator shall be mounted as follows:

- *Fig. 3-11* indicates the closed position
- *Fig. 3-12* indicates the open position

Optionally the rotary actuator actubar can be mounted **transversely to the pipeline**. The position indicators are mounted as follows:

- *Fig. 3-11* indicates the open position
- *Fig. 3-12* indicates the closed position

NOTE

Make sure that the optical position indicator together with a ball valve always corresponds to the ball bore or, in the case of a butterfly valve, always corresponds to the disc.

3.6 Accessories

DANGER

Danger of explosion

An explosion can occur if components are operated with insufficient protection class and without approved explosion protection.

- When selecting the pneumatic valves and the accessories, pay attention to the combination with Ex-approved products..

Contact your bar customer service for selection of the right accessories:

- Auxiliary products from the vacotrol series with direct air flow
- Throttle plates
- Silencer
- End position feedback devices
- Solenoid valves
- Positioner

4. Transport and storage

4.1 Scope of delivery

- Pneumatic rotary actuator actubar
- Possibly ordered accessories

4.1.1 Incoming goods inspection

The following items must be checked at the time of delivery:

- Does the number of delivered transport containers correspond to the delivery note?
- Is the packaging free of visible damage?
- Are the product and accessories free of visible damages?
- Are there any evidences of not gentle handling during the transport (e.g., burns, scratches, colour)?

To have all the right for claim against the transport company, you have to document the possible external transport damages (e.g. with photographs and a written protocol) before unpacking the product.

bar GmbH is not responsible for transport damages and can take over no liability for that.

4.2 Transport, packaging and storage

DANGER



Suspended load!

When transporting, e.g. with a crane, there is a risk that parts fall down and people are seriously injured.

- Never exceed the permissible load of the hoisting equipment used.
- Use only suitable, approved and undamaged lifting slings for transport.
- If you connect the slings to the rotary actuator, they may only be used to transport the rotary actuator and not for the entire control device.
- Connect the slings so that the products can not be damaged.
- Exercise the utmost care when handling and balancing the load.
- Perform the works with constant eye contact with the load.
- Do not stay under or near the lifted load.
- Keep third persons out of the danger zone. Use appropriate barriers or name supervisors.

NOTE

If lifting slings are required for transport, they must be connected in such a way that the products are not damaged.

Lifting slings are mounted at the factory from size 160 (type AD/AS-160). The supplied slings are intended solely for the transport of the products to which they are mounted.

The products must be handled, transported and stored with care:

- There is no liability of the manufacturer for transport within the customer's territory or to the individual places of use.
- The products should be transported in their original packaging or on a pallet (or similarly supported) to the installation site and unpacked immediately before installation.
- When storing before installation, keep the products in a closed room and protect them from harmful influences such as dirt or moisture.
- The products must be stored in their original packaging and, if necessary, with the appropriate protective covers.
- In case of a longer storage period, the pneumatic rotary actuator must be operated at least once a year.
- Proper disposal of the packaging is the responsibility of the customer.

5. Installation

WARNING

Installation works

There is a risk of injury if this product is not properly installed, disassembled and put into operation.

- Make sure the personnel has received the appropriate training.
- Observe the safety instructions in „Chapter 2. Safety“.

NOTE

Check the technical parameters, in particular pressure and temperature, and the electrical voltage of the control valve before installing or commissioning the rotary actuator.

5.1 Installation conditions

The minimum space requirement can be found in the dimension drawing or dimension table („Chapter 1. Annex / Technical data“).

5.2 Before installation

Observe the following points before installation:

- The dew point of the control medium must be min. 10 °C lower than the lowest operating temperature! The max. temperature of the control medium is 45 °C!
- The rotary actuator is not suitable for accepting external lateral forces on the pinion as well as for permanent torsional vibrations in the end positions.

- When operating valves, considerable kinetic energy can be generated which is transmitted to the actuator. The user must ensure that the rotary actuator is adequately protected and that the below-mentioned switching times for soft-sealing flaps and standard ball valves for pure 90° rotary movement are not exceeded.

The following minimum times for the rotary movement of 90° must be observed:

Type (AD/AS)	Switching times
001 till 018	0,1 sec
026 till 050	0,2 sec
076 till 110	0,4 sec
160 till 230	0,7 sec
360 till 1200	1,0 sec

Tab. 5-1 actubar minimum times for the rotary movement of 90°

The switching time can be reduced and adjusted by using silencers or throttle plates from our range of accessories.

We recommend hydraulic damping for critical applications.

For other valve types, in particular large-volume valves with low torque requirement, the operating conditions of the rotary actuator must be agreed with the manufacturer. We will be delighted to advise you.

5.3 Installation of the valve

MV*	Basic position		Swivel direction	Switched position	
	Piston position	Position indicator		Piston position	Position indicator
F					
E					
G					
H					

* MV = Mounting variants

**Tab. 5-2 Mounting variants for rotary actuator actubar (see also type plate)
View from above**

Left-turning mounting variants F/E

Left-turning means that the actuator rotates counterclockwise when pneumatic port 2 is pressurized.

Right-turning mounting variants H/G

Right-turning means that the actuator rotates clockwise when pneumatic port 2 is pressurized.

Left-turning opening - Right-turning closing

In general, valves are opened by turning to the left, i.e. counterclockwise, and closing by turning to the right, i.e. clockwise.

With the appropriate selection of mounting variant you can thus ensure with single-acting rotary actuators that the valve is closed (spring force closing: F/E) or opened (spring force opening: H/G) in case of pressure failure.

Make sure that the optical position indicator together with a ball valve or flap always corresponds to the ball bore/disc.

Make sure that the maximum torques of the flange pattern used are not exceeded for the sake of design and operation!

Connecting surfaces must be free from oil and grease, clean and dry.

1. Place the rotary actuator on the valve spindle (7). If necessary, install prior required components such as, for example, shaft adapter, reduction, mounting bridges and/or centering.
2. Slightly grease the connecting bolts.
3. Tighten the connecting screws on the flange pattern according to Tab. 5-3.
4. If necessary, remove unnecessary red clip from the position indicator.

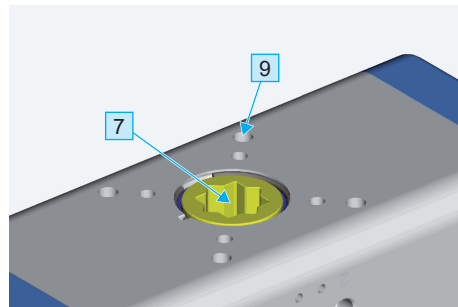

Fig. 5-1 View on rotary actuator from bottom = valve interface

- 7 Installation of the valve spindle / shaft adapter
- 9 Installation of connecting screws

Observe the following tightening torques when installing connecting bolts:

Flange pattern	Screw size	Tightening torque [Nm]
F03	M5	6
F04	M5	10
F05	M6	10
F07	M8	25
F10	M10	49
F12	M12	85
F14	M16	145
F16	M20	310
F25	M16	145

Tab. 5-3 Tightening torques for connecting-screws of rotary actuator – valve

5.4 Installation of the pneumatic connection

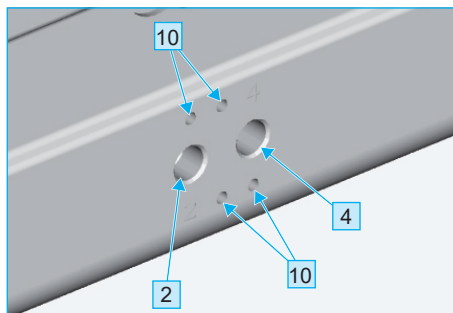

Fig. 5-2 Pneumatic connections of the rotary actuator actubar up to size AD/AS-230

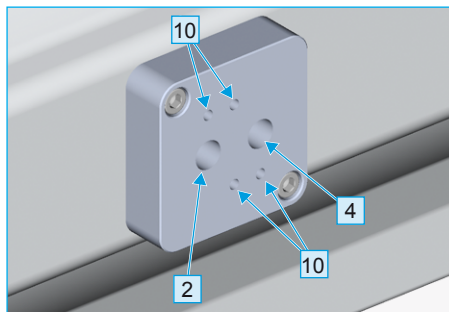

Fig. 5-3 Pneumatic connections of the rotary actuator actubar AD/AS 360 till 1200

- 2** Pneumatic connection
- 4** Pneumatic connection
- 10** Threaded hole M5, at air connection 1/2" M6

The single-acting rotary actuators are equipped with a silencer in the pneumatic connection 4 at the factory. Remove this before you connect NAMUR control valve.

Pneumatic connection for single-acting rotary actuators:

- Remove silencer in the pneumatic connection 4.
- Connect the pneumatic connection 2 to the compressed air supply line.

Pneumatic connection for double-acting rotary actuators:

- Connect the pneumatic connections 2 and 4 to the compressed air supply lines.

5.4.1 Installation of the vacotrol interface

⚠ WARNING

Ejected parts!

If the vacotrol interface is opened under pressure, there is a risk of parts being ejected!

- Always disconnect the compressed air supply before maintenance, disassembly and repair!
- Never dismount the threaded pins of the vacotrol interface under pressure..

The actubar rotary actuator optionally offers (starting from size 008) an additional pneumatic valve interface (vacotrol interface) on the upper side of the drive which enables a direct pneumatic connection without pipes and hoses when using the appropriate auxiliary components.

To use the vacotrol Interface, proceed as follows:

1. Remove two threaded pins (11) on the top.
2. Close and seal the pneumatic connections 2 and 4.

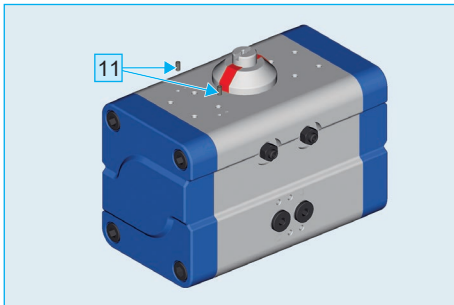

Fig. 5-4 Vacotrol interface of the rotary actuator

NOTE

Close both top connections, if the vacotrol interface is no longer used. Use liquid seal and make sure that the threaded pins (11) are screwed in evenly.

5.5 Pressure test of the pipe section

The following must be observed when making the pressure test of a pipe section with installed valves:

Carefully rinse newly installed piping systems to flush out any foreign objects.

Valve opened:

- The test pressure must not exceed the value of $1.5 \times PN$ as marked on the housing.

Valve closed:

- The test pressure must not exceed the value of $1.1 \times PN$ as marked on the housing.

6. Commissioning and operation

6.1 General information for commissioning of different variants

The actubar rotary actuator (with the exception of sizes AD-001 and AD/AS-002) is equipped as standard with a mechanical end position setting unit on both sides.

The size AD-001 has a fixed stop at 0° and 90°.

The size AD/AS-002 has a fixed stop at 0°, the end position at 90° is adjustable via cover screws.

For bar ball valves with pneumatic actuator, the end positions are pre-adjusted to 0° and 90° at factory. In case of bar GmbH automated butterfly valves with pneumatic actuator, the end positions are set at the factory in such a way that the butterfly valve opens approx. 4° when closed and 90° when opened. The automated valves are checked for function.

If you would like to make a new adjustment or alignment of the mechanical end positions on the rotary actuator actubar, please observe the adjustment range of the mechanical swivel angle according to *Fig. 6-1* as well as the following notes and descriptions

6.2 Setting the end positions

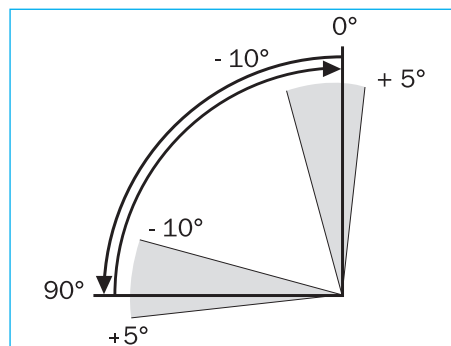

Fig. 6-1 Adjustable mechanical swivel angle range of the actubar version 90° from size AD/AS-004

WARNING

Ejected parts!

If the end stops are misaligned under pressure, the vacotrol interface or the rotary actuator itself is opened, there is a risk of parts being ejected!

- Always disconnect the compressed air supply before maintenance, disassembly and repair!
- Never set the mechanical end positions on the rotary actuator as long as there is pressure on connection 2 or 4.
- Make sure the pinion of the rotary actuator is moving in the correct direction.

Basically, the following applies:

The adjusting screws have a right-hand thread.

- Screwing in = turning clockwise reduces the swivel angle.
- Screwing out = turning counterclockwise increases the swivel angle.

For safety reasons, the adjusting screws may be screwed in or out by a maximum of 1-2 turns depending on the actuator size.

Turning in or out by 1 turn corresponds to an angle adjustment of up to 5°.

The adjusting screws must only be screwed out so far that the screw heads protrude only a few millimeters beyond the lock nut on the actuator housing.

When screwing in, make sure that the adjusting screws remain completely in the thread of the lock nut on the actuator housing.

Observe the following tightening torques when tightening the lock nuts:

Type (AD/AS)	Nut size	Tightening torque [Nm]
002 till 008	M6	9
011 till 026	M8	17
037 till 050	M10	32
076 till 110	M12	62
160 till 230	M16	160
360 till 520	M20	315
800 till 1200	M27	800

Tab. 6-1 Tightening torques for lock nuts actubar

6.2.1 End position setting Type AD/AS-002

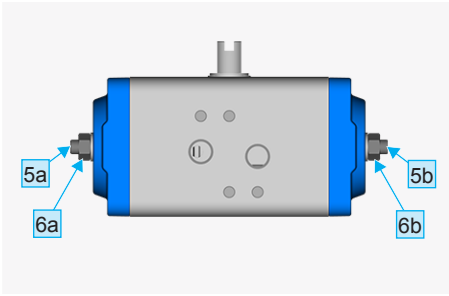

Fig. 6-2 Adjustment of the rotary actuator actubar AD/AS-002

- 6a** Lock nut
- 5a** Adjusting screw
- 6b** Lock nut
- 5b** Adjusting screw

The drive type AD/AS-002 has a fixed stop in the basic position.

The switched position can be adjusted. This is the open valve position for mounting variants F and E and the closed valve position for mounting variants H and G (see *Tab. 5-2*).

1. If this is not already the case, allow the actuator to swing into the closed position and vent the actuator.
 - Double-acting actuators: Supply compressed air to port 4, then bleed air.
2. Loosen the lock nuts (6a,6b) of the adjusting screws (5a,5b) on both covers. Unscrew the left adjusting screw (5a) slightly counterclockwise.
3. Make the adjustment with the right adjusting screw (5b) and lock it with the lock nut (6b).
4. Swivel the valve into the switching position (supply connection 2 with compressed air) and check the end position setting.
5. If the setting is correct, turn the left adjusting screw (5a) clockwise into the thread until you notice a resistance and touch the piston. Lock the adjustment screw (6b). Both adjusting screws are thus screwed in symmetrically. Move the actuator to the basic position (vent connection 2 and, in case of double-acting actuators, supply connection 4 with compressed air) and after that vent the actuator.
6. If the setting needs to be corrected again, repeat steps 3 to 5.

6.2.2 End position setting Type AD/AS-004 till 1200

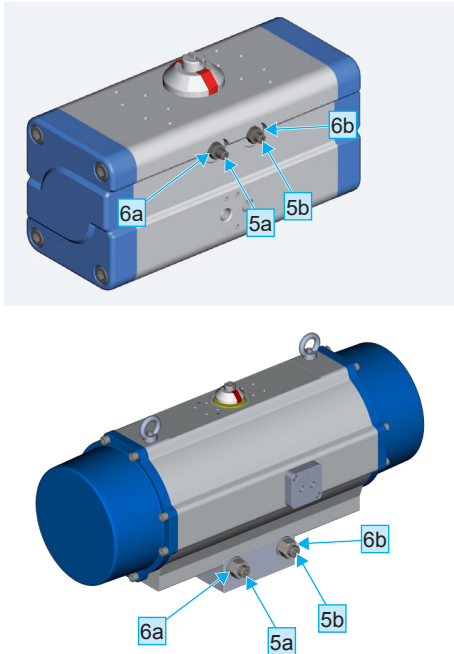

Fig. 6-3 Adjustment of the rotary actuator actubar AD/AS-004 till 230 (top) AD/AS-360 till 1200 (bottom)

- 6a** Lock nut
- 5a** Adjusting screw
- 6b** Lock nut
- 5b** Adjusting screw

6.2.2.1 Adjustment of swivel angle for mounting variants F/E

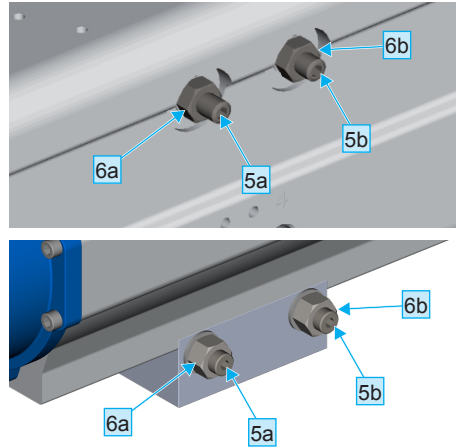

Fig. 6-4 Adjustment of the rotary actuator actubar in details AD/AS-004 till 230 (top) AD/AS-360 till 1200 (bottom)

Setting the closed valve position

1. If this is not already the case, allow the actuator to swing into the closed position.
 - Double-acting actuators: Supply compressed air to port 4, then bleed air.
2. Loosen the lock nut (6b) of the adjusting screw (5b).
3. Adjust the closed valve position with the adjusting screw (5b) and lock the adjusting screw with the lock nut.
4. Open and close the valve and check the setting. If necessary, repeat the points 1 to 4. If you also want to adjust the other end position, continue with point 5.

Setting the open valve position

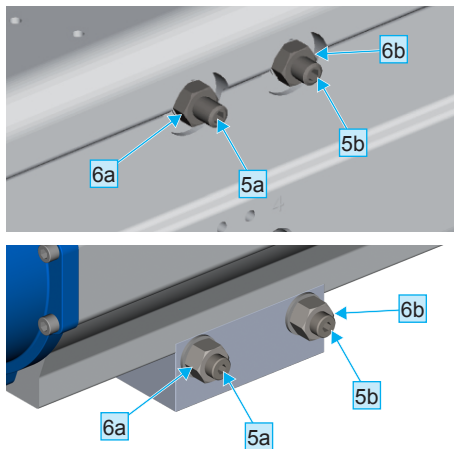

Fig. 6-5 Adjustment of the rotary actuator actuator in details AD/AS-004 till 230 (top) AD/AS-360 till 1200 (bottom)

1. If this is not already the case, allow the actuator to swing into the closed position and vent the actuator.
2. Loosen the lock nut (6a) of the left adjusting screw (5a) and make the adjustment with the adjusting screw. Lock the adjusting screw with the lock nut.
3. Open and close the valve and check both end positions.
4. If the opening angle is correct, return the actuator to the closed position and vent the actuator. If the setting needs to be corrected again, repeat points 5 to 8.

6.2.2.2 Adjustment of swivel angle for mounting variants G/H

Setting the open valve position

1. If this is not already the case, allow the actuator to swing into the closed position.
 - Double-acting actuators: Supply compressed air to port 4, then bleed air.
2. Loosen the lock nut (6b) of the right adjusting screw (5b).
3. Adjust the open valve position with the adjusting screw (5b) and lock the adjusting screw with the lock nut.
4. Close and open the valve and check both end positions. If necessary, repeat the points 1 to 4. If you also want to adjust the other end position, continue with point 5.

Setting the closed valve position

1. If this is not already the case, allow the actuator to swing into the open position and vent the actuator.
2. Loosen the lock nut (6a) of the left adjusting screw (5a) and make the adjustment with the adjusting screw. Lock the adjusting screw with the lock nut.
3. Close and open the valve and check both end positions.
4. If the setting is correct, return the actuator to the open position and vent the actuator. If the setting needs to be corrected again, repeat points 5 to 8.

7. Maintenance and repair

The pneumatic rotary actuator actubar is maintenance-free.

In terms of operational safety, however, it is recommended to check them for function and to switch at least once a year but no later than after 50,000 switching cycles.

Do not use harsh detergents or abrasives to clean the housings. In principle, it is possible to repair the pneumatic rotary actuator by replacing the seal and wear parts sets.

NOTE

We recommend that you have the repair carried out by the company bar GmbH! We will be pleased to offer you a corresponding servicing, maintenance or repair! Please contact the company bar GmbH for this.

8. Troubleshooting

WARNING

Observe the safety instructions

There is danger to life if you do not observe safety instructions.

- When eliminating the faults, always observe the safety instructions from „Chapter 2. Safety“.

NOTE

Spare parts are to be ordered with all information on the type plate and the serial number. It is allowed to mount only original parts of bar GmbH.

9. Repair and spare parts

9.1 Type AD-001 (schematic diagram)

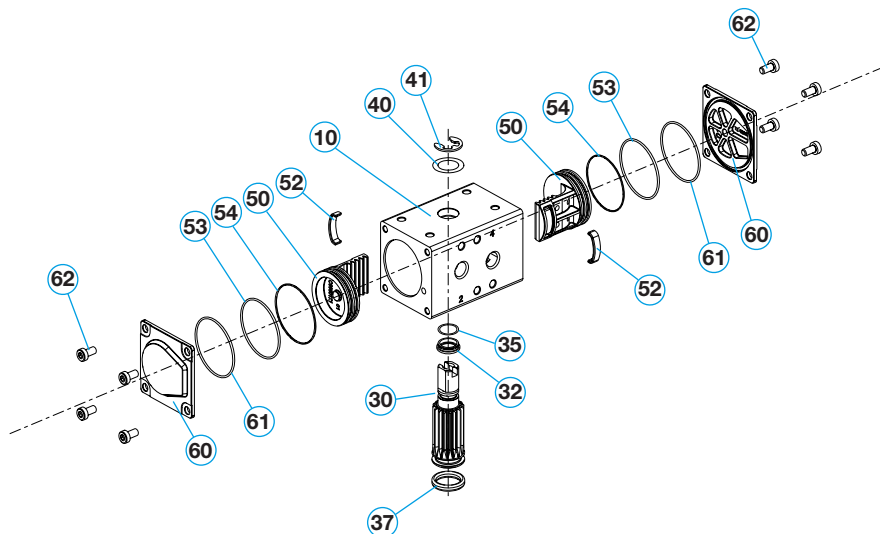

Fig. 9-1 Exploded-view drawing of all individual components of rotary actuator actubar

10	Casing	40	Supporting ring	54	Piston seal
30	Pinion	41	Lock washer	60	Cover
32	Upper pinion bearing	50	Piston	61	Cover seal
35	Upper pinion seal	52	Guiding shoe	62	Cover screws
37	Lower pinion seal	53	Guiding ring		

Spare parts sets:

- Sealing set consists of: 35, 37, 54, 61
- Wear parts set consists of: 32, 52, 53

AD	-	001	/	090	-	V22	F
Operating way		Type		Swivel angle 90°		Pinion design	Installation variants
S = Single-acting D = Double-acting					Number of springs	V = Octagon with dimensions Z = Two-flats with dimensions	

Tab. 9-1 Order code actubar (example)

9.2 Type AD/AS-002 (schematic diagram)

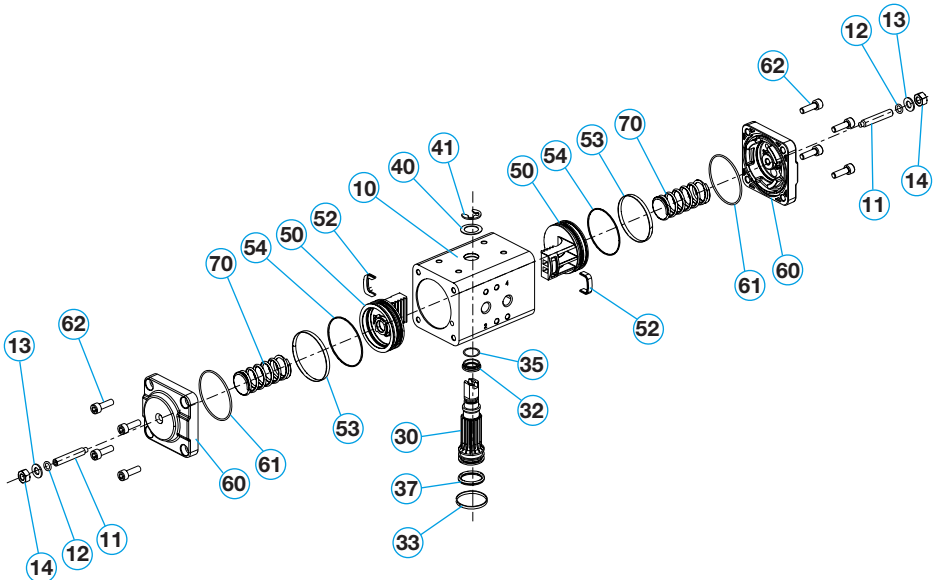

Fig. 9-2 Exploded-view drawing of all individual components of rotary actuator actubar

10	Casing	33	Lower pinion bearing	53	Guiding ring
11	Stop screw	35	Upper pinion seal	54	Piston seal
12	Seal of stop screw	37	Lower pinion seal	60	Cover
13	Washer	40	Supporting ring	61	Cover seal
14	Lock nut	41	Lock washer	62	Cover screws
30	Pinion	50	Piston	70	Spring (type AS)
32	Upper pinion bearing	52	Guiding shoe		

Spare parts sets:

- Sealing set consists of: 12, 35, 37, 54, 61
- Wear parts set consists of: 32, 33, 52, 53

AD	-	002	/	090	-	01	-	Z... V22	A
AS	-	002	/	090	-	01	-	V22	F
Operating way		Type		Swivel angle 90°		Number of springs		Pinion design	Installation variants
<p>S = single-acting D = Double-acting</p> <p>V = Octagon with dimensions Z = Two-flats with dimensions</p>									

Tab. 9-2 Order code actubar (example)

9.3 Type AD/AS-004 till 230 (schematic diagram)

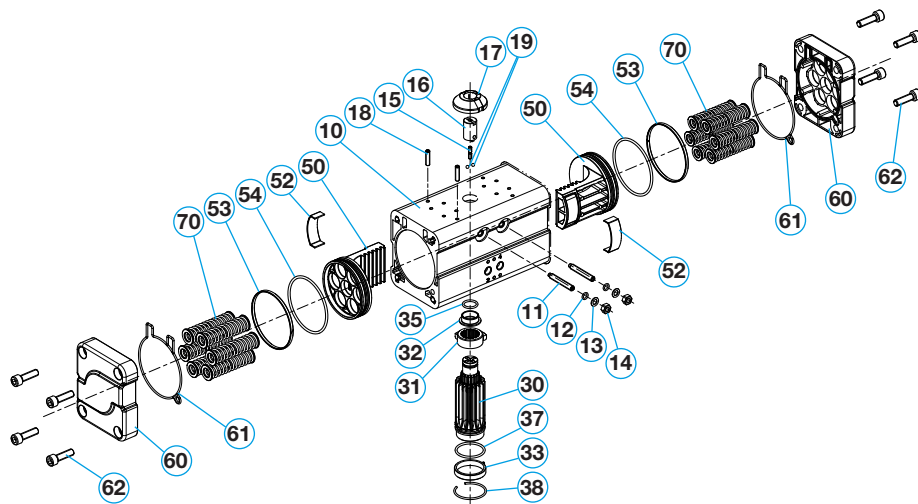

Fig. 9-3 Exploded-view drawing of all individual components of rotary actuator actubar

10	Casing	19	Coding balls	52	Guiding shoe
11	Stop screw	30	Pinion	53	Guiding ring
12	Seal of stop screw	31	Stop cam	54	Piston seal
13	Washer	32	Upper pinion bearing	60	Cover
14	Lock nut	33	Lower pinion bearing	61	Cover seal
15	Threaded pin	35	Upper pinion seal	62	Cover screws
16	Namur shaft	37	Lower pinion seal	70	Spring (Type AS)
17	Position indicator	38	Round wire ring		
18	Vacotrol seal screw*	50	Piston		

Spare parts sets:

- Sealing set consists of: 12, 18, 35, 37, 54, 61
- Wear parts set consists of: 32, 33, 52, 53

* optional

AD	-	050	/	090	-	Z...	-	A
AS	-	050	/	090	-	V22	-	F
Operating way		Type		Swivel angle 90°	Number of springs	Pinion design		Installation variants
S = Single-acting						V = Octagon with dimensions		
D = Double-acting						Z = Two-flats with dimensions		

Tab. 9-3 Order code actubar (example)

9.4 Type AD/AS-360 till 1200 (schematic diagram)

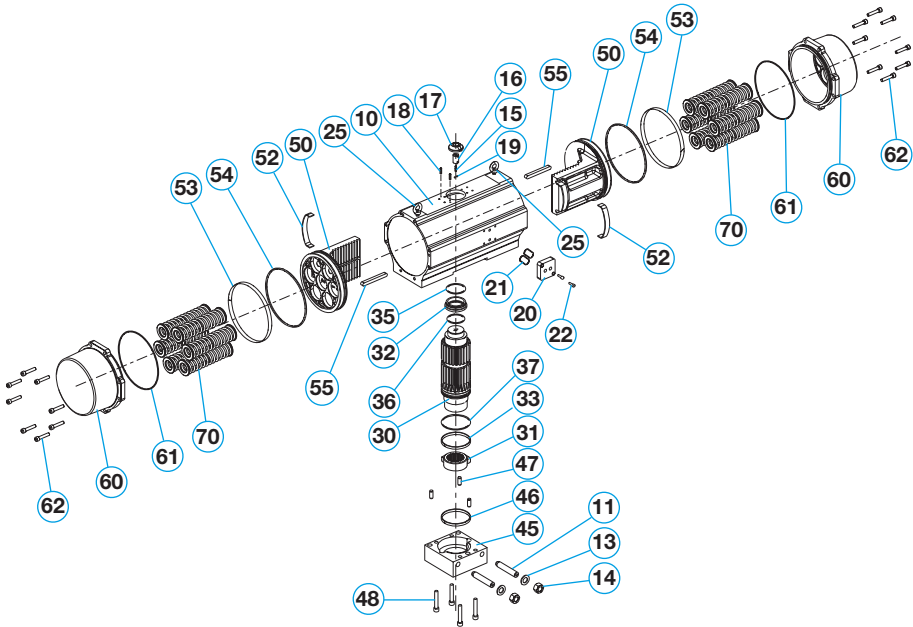

Fig. 9-4 Exploded-view drawing of all individual components of rotary actuator actubar

10	Casing	22	Screws	47	Cylinder pins
11	Stop screw	25	Ring nut	48	Flange screws
13	Washer	30	Pinion	50	Piston
14	Lock nut	31	Stop cam	52	Guiding shoe
15	Threaded pin	32	Upper pinion bearing	53	Guiding ring
16	Namur shaft	33	Lower pinion bearing	54	Piston seal
17	Position indicator	35	Upper pinion seal	55	Feather key
18	Vacotrol seal screw*	36	Upper bearing seal	60	Cover
19	Coding balls	37	Lower pinion seal	61	Cover seal
20	Namur adapter plate	45	Flange plate	62	Cover screws
21	Seal	46	Bearing flange plate	70	Spring (Type AS)

- Sealing set consists of: 18, 21, 35, 36, 37, 54, 61
- Wear parts set consists of: 32, 33, 46, 52, 53

* optional

A D	-	360	/	090	-	Z...	A
AS	-	360	/	090	-	V22	F
Operating way		Type		Swivel angle 90°		Pinion design	Installation variants
				Number of springs			

S = Single-acting

D = Double-acting

V = Octagon with dimensions

Z = Two-flats with dimensions

Tab. 9-4 Order code actubar (example)

10. Disassembly

WARNING

Installation works

There is a risk of injury if this product is not properly installed, disassembled and put into operation.

- Make sure the personnel has received the appropriate training.
- Observe the safety instructions in „Chapter 2. Safety“.

10.1 Disassembly of the rotary actuator

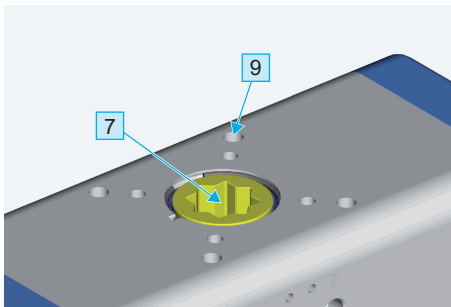

Fig. 10-1 Disassembly of the rotary actuator from the valve
(view on actuator from below = valve interface)

- 7** Installation of the valve spindle / shaft adapter
- 9** Installation of connecting screws

To disassemble the valve, proceed as follows:

1. Loosen the connecting screws (9) between the valve and the rotary actuator.
2. Remove the rotary actuator from the valve spindle.
3. Remove any additional parts such as shaft adapter, reducer, mounting bridge and/or centering and store them carefully.

11. Disposal

- Proper disposal of the products is the responsibility of the customer. Dispose of the products after their use in accordance with the legal requirements regarding safety and environmental protection.
- The materials used in the products are steel, aluminum, brass and various plastics.

Dispose of lubricated parts separately according to local environmental regulations!

If you have any questions, please contact the company bar GmbH.

12. EU Declarations

12.1 Declaration of incorporation according to Directive 2006/42/EG

This is a representation of the contents of the declaration of incorporation. The signed declaration of incorporation can be found at www.bar-gmbh.de

We hereby declare that the incomplete machine described below - insofar as it is possible from the scope of delivery - complies with the basic requirements of the EC Machinery Directive listed below.

Commissioning of the incomplete machine is prohibited until the incomplete machine has been installed in a machine and it complies with the provisions of the EC Machinery Directive and the EC declaration of conformity in accordance with Annex II A is available.

We further declare that the specific technical documentation for this incomplete machine has been prepared in accordance with Annex VII, Part B and undertake to forward it to the competent national authorities through our documentation department upon a reasoned request.

Machine type	Pneumatic actuator
Machine designation	actubar type AD/AS
Year of construction	From 2018
Relevant EC Directives	2006/42/EG
Fulfilled requirements of MD 2006/42/EC, Annex I Part 1	1.1.3, 1.1.5, 1.3.2, 1.3.4, 1.3.7, 1.3.9, 1.5.3, 1.5.4, 1.5.5, 1.5.7, 1.5.8, 1.7.3, 1.7.4
Applied harmonized standards	EN ISO 12100:2010
Applied national standards and technical specifications	None

Manufacturer and name of authorized representative responsible for the technical documentation:

bar pneumatische Steuerungssysteme GmbH
 Auf der Hohl 1
 53547 Dattenberg
 Tel.: +49 (0)2644-9607-0
 Fax: +49 (0)2644-960735
 E-Mail: bar-info@wattswater.com

Place and date of issue: Dattenberg, 20.12.2017

Thomas Wild, Sales manager

12.2 ATEX-Declaration of Conformity



bar 19.0001

Z5000002_00B

A WATTS Brand

Auf der Hohl 1 | 53547 Dattenberg | Germany | T: +49 (0)2644 9607-0 | F: +49 (0)2644 9607-35

ATEX-Konformitätserklärung / ATEX Declaration of Conformity

Name und Anschrift des Herstellers: **bar pneumatische Steuerungssysteme GmbH**
 Name and address of the manufacturer: **Auf der Hohl 1, 53547 Dattenberg / Germany**

Diese Erklärung bezieht sich nur auf das Produkt in dem Zustand, in dem es in den Verkehr gebracht wurde. Die Erklärung verliert ihre Gültigkeit, wenn das Produkt ohne Rücksprache mit uns umgebaut oder verändert wird.

This declaration relates exclusively to the product in the state in which it was placed on the market. The declaration loses validity, if the product is modified without agreement of company bar.

Hiermit erklären wir, dass das nachstehend beschriebene Produkt
 Herewith we declare, that the following product

Produktbezeichnung: **pneumatischer Stellantrieb**
 Product denomination: **pneumatic actuator**
 Serien-/Typenbezeichnung / model/type: **actubar Typ AD/AS/CAD/CAS**

nach den Anforderungen folgender Richtlinien hergestellt wurde:
 was manufactured according to the following directives:

2014/34/EU ATEX-Richtlinie / ATEX – directive (EU-Abt. L 96/309 vom 29.03.2014)

Die Einhaltung der in den technischen Daten und Sicherheitshinweisen beschriebenen Betriebsbedingungen ist sicherzustellen. Der anlagenseitige elektrische Potentialausgleich der Anbauteile ist zu prüfen und über die gesamte Einsatzzeit sicherzustellen.

Please take care about the technical data and the relevant warning and safety notices. Check the electrical equipotential bonding of all parts and ensure it during whole operating time.

Gerätekennzeichnung / Designation:

II 2 G Ex h IIC T6..T3 Gb
 II 2 D Ex h IIIC T180°C Db

Max. Oberflächen-temperatur max. surface temperature	Max. zulässige Umgebungstemperatur max. permissible ambient temperature	Antriebsversion actuator version
T6 (85°C)	-40°C / -20°C < T _a < +65°C	Tieftemperatur* oder Standard Deep Temperature* or Standard
T5 (100°C)	-40°C* / -20°C < T _a < +80°C	Tieftemperatur* oder Standard Deep Temperature* or Standard
T4 (135°C)	-20 < T _a < +115°C	FKM-Version oder Hochtemperatur FKM-Version or High Temperature
T3 (200°C)	-20°C < T _a < +160°C	Hochtemperatur High Temperature

Angewandte harmonisierte Normen: *Where appropriate harmonised Standards used:*

DIN EN ISO 80079-36:2016 Explosionsfähige Atmosphären – Explosive atmospheres
 Teil 36: Nicht-elektrische Geräte für den Einsatz in explosionsfähigen Atmosphären – Grundlagen und Anforderungen
 Part 36: Non-electrical equipment for explosive atmospheres – Basic method and requirements
 DIN EN ISO 80079-37:2016 Explosionsfähige Atmosphären – Explosive atmospheres
 Teil 37: Nicht-elektrische Geräte für den Einsatz in explosionsfähigen Atmosphären – Schutz durch konstruktive Sicherheit
 „c“ [...] Part 37: Non-electrical equipment for explosive atmospheres – Non-electrical type of protection constructional safety “c”

Dattenberg, 19.03.2020
 Ort, Datum
 Place, Date

Wood, Nigel, Managing Director
 Name, Vorname und Funktion des Unterzeichners
 Surname, first name and function of signatory

Unterschrift
 Signature



Deutsche Bank Neustadt Weinstraße • SWIFT DEUTDE33 • IBAN DE35 5467 0095 0022 8114 00
 Deutsche Bank Amsterdam • SWIFT DEUTNL2N • IBAN NL52 DEUT 0319 8666 53
 HRB 10991 Amtsgericht Montabaur • Ust-Nr. DE 149 522 999
 Geschäftsführer: Olivier Givardon, Nigel Wood
 bar-info@wattswater.com

bar-gmbh.de

13. Annex / Technical data

13.1 Technical data

	Standard design	Upon request
Construction type	Pneumatic twin-piston rotary actuator Type AD = double-acting Type AS = single-acting (with spring return))	Pneumatic valve interface (vacotrol interface) Design with hydraulic damping
Design features	Rack-and-pinion principle with self-centering piston guide in the housing; single-acting: with bar safety springs	
Mounting position	any	
Standards	Connection point actuator/signal device acc. to: VDI/VDE 3845 (NAMUR) and VDI/VDE 3847 Connection point actuator/control valve acc. to: NAMUR or VDI/VDE 3845 Connection point actuator/valve: four or eight internal threads in the actuator housing acc. to EN ISO 5211	Different mounting and connection dimensions are possible Drive pinion optionally with bore with two-flats acc. to: EN ISO 5211 or according to customer requirements
Materials	Housing: Al-alloy, anodized or powder coated Cover: Al-alloy, powder-coated Piston/rack: Al-alloy Pinion: corrosion-protected steel Seals: NBR Bearings: out of low-friction plastic Screws: Stainless steel A2	Housing coating: Hard coated; powder-coated; PTFE Cover coating: PTFE Pinion: Stainless steel AISI 303; AISI 316 Seals: FKM
Ambient temperature	-20 °C to +80 °C	Low temperature design: -40 °C to +80 °C High temperature design: -20 °C to +160 °C
Nominal swivel angle	double- and single-acting: 90° Nominal swivel angle can be adjusted as standard from + 5° to -10° in both end positions	
Torque	2,5 Nm to 9.600 Nm	
Control pressure	2 to 8 bar	
Control medium/quality	Filtered compressed air, ISO 8573-1:2010 [7:-:4], dew point min. 10 °C under lowest operating temperature	Upon request also can be operated with other nonaggressive, gaseous or liquid media

Tab. 13-1 Technical data

13.2 Dimensional drawings for actubar type AD-001

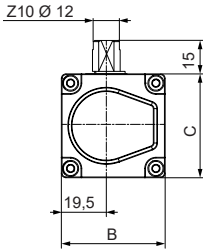

Fig. 13-1 Dimensional drawing actubar type AD-001

13.3 Dimensional drawings for actubar type AD/AS-002

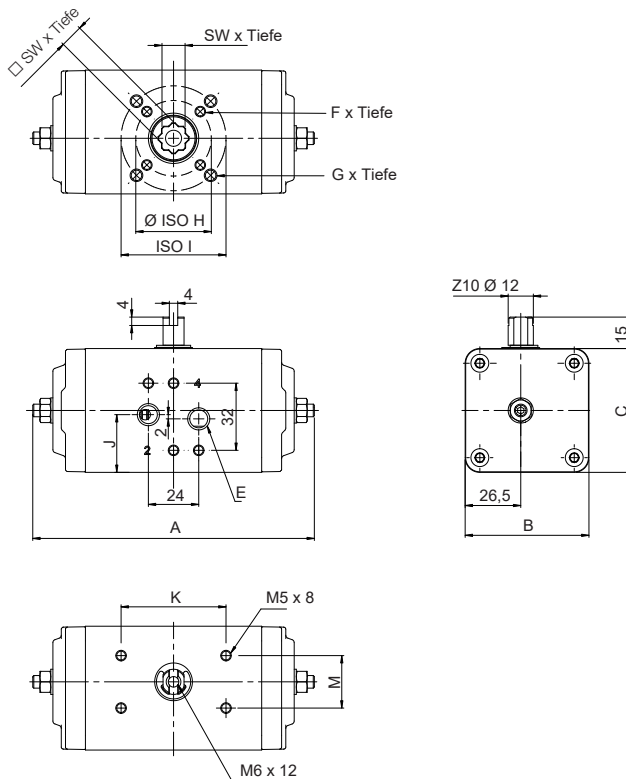

Fig. 13-2 Dimensional drawing actubar type AD/AS-002

13.4 Dimensional drawings for actubar type AD/AS-004 and 006

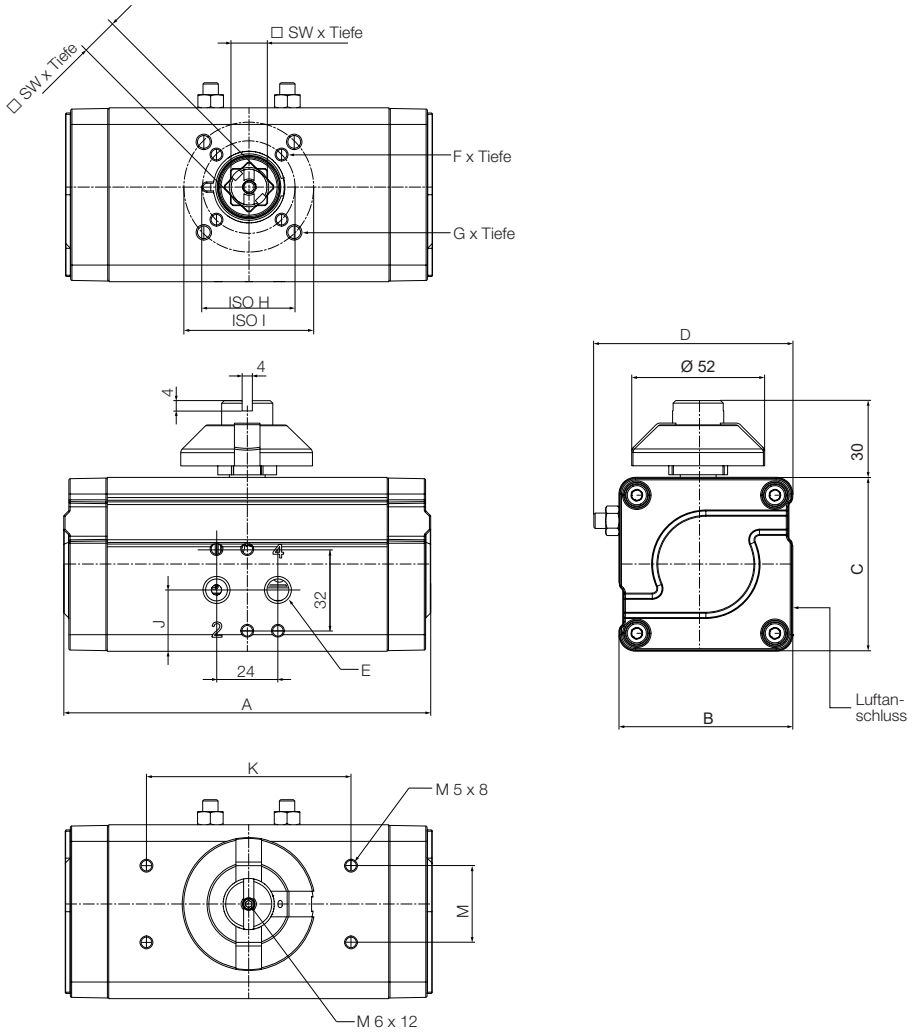

Fig. 13-3 Dimensional drawing actubar type AD/AS-004 and 006

13.5 Dimensional drawings for actubar type AD/AS-008 till 230

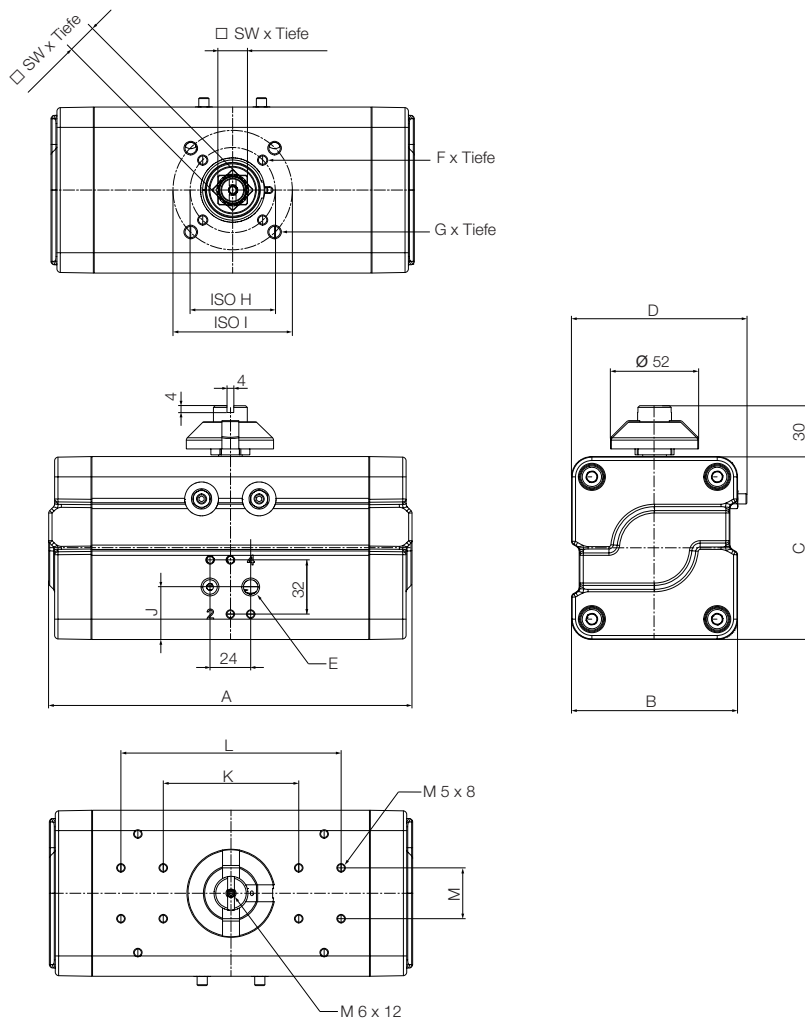

Fig. 13-4 Dimensional drawings for actubar type AD/AS-008 till 230

13.6 Dimensional drawings for actubar type AD/AS-360 till 1200

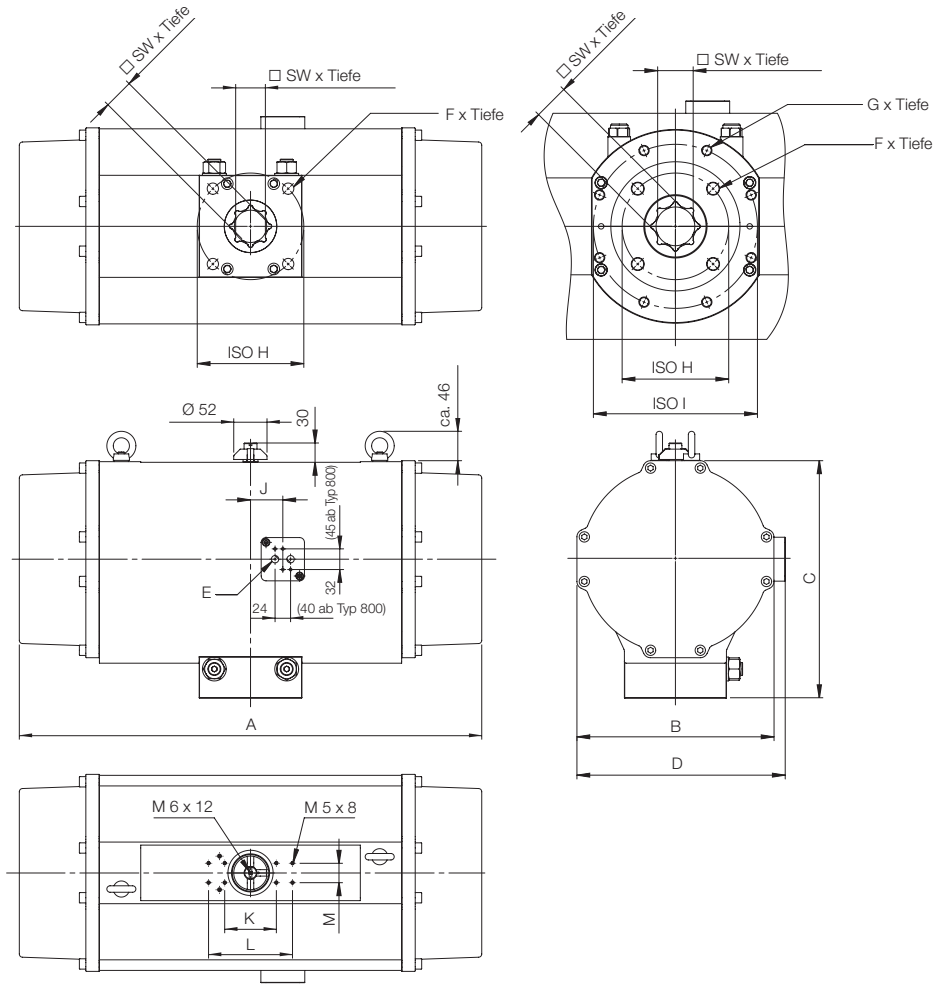

Fig. 13-5 Dimensional drawings for actubar type AD/AS-360 till 1200

13.7 Measurement chart

Type AD/AS	A	B	C	D	E	F x depth	G x depth
001	80	45	45		G 1/8"	M5x8	
002	134	59	59		G 1/8"	M5x8	M6x9
004	144	68	68	82	G 1/8"	M5x8	M6x9
006	159	76	84	90	G 1/8"	M6x9	M8x12
008	173	98	108	109	G 1/8"	M6x9	M8x12
011	215	98	108	109	G 1/8"	M6x9	M8x12
018	213	114	132	127	G 1/4"	M6x9	M8x12
026	281	114	132	127	G 1/4"	M8x12	M10x15
037	266	138	161	155	G 1/4"	M8x12	M10x15
050	347	138	161	155	G 1/4"	M8x12	M10x15
076	329	176	200	196	G 1/4"	M10x15	M12x18
110	475	176	200	196	G 1/4"	M10x15	M12x18
160	516	199	220	225	G 1/4"	M10x15	M12x18
230	560	223	244	249	G 1/4"	M16x24	
360	696	260	320	282	G 1/4"	M20x30	
520	716	305	368	326	G 1/4"	M20x30	
800	725	353	424	375	G 1/2"	M20x30	M16x30
1200	953	416	486	436	G 1/2"	M16x30	

Tab. 13-2 Measurement chart for actubar type AD/AS-001 till 1200

Measurement chart

Type AD/AS	ISO H	ISO I	J	K	L	M	SW x depth
001	Ø36/F03		22,5	50		25	9x12
002	Ø36/F03	Ø50/F05	27,5	50		25	11x13
004	Ø36/F03	Ø50/F05	24	80		30	14x17
006	Ø50/F05	Ø70/F07	32	80		30	14x17
008	Ø50/F05	Ø70/F07	31	80		30	14x17
011	Ø50/F05	Ø70/F07	31	80	130	30	17x20
018	Ø50/F05	Ø70/F07	35	80	130	30	17x20
026	Ø70/F07	Ø102/F10	35	80	130	30	22x25
037	Ø70/F07	Ø102/F10	40,5	80	130	30	22x25
050	Ø70/F07	Ø102/F10	40,5	80	130	30	22x25
076	Ø102/F10	Ø125/F12	50	80	130	30	27x30
110	Ø102/F10	Ø125/F12	50	80	130	30	27x30
160	Ø102/F10	Ø125/F12	60	80	130	30	27x30
230	Ø140/F14		72	80	130	30	36x40
360	Ø165/F16		50	80	130	30	46x50
520	Ø165/F16		50	80	130	30	46x50
800	Ø165/F16	Ø254/F25	50		130	30	55x58
1200	Ø254/F25		50		130	30	55x58

Tab. 13-3 Measurement chart for actubar type AD/AS-001 till 1200

13.8 Weight and volume

Type AD/AS	Weight	Volume/double stroke	Weight*	Volume/double stroke
	AD [kg]	AD [L]	AS [kg]	AS [L]
001	0,34	0,05	/	/
002	0,73	0,15	0,84	0,06
004	1,21	0,25	1,38	0,09
006	1,81	0,41	2,04	0,19
008	2,97	0,60	3,13	0,20
011	3,59	0,85	3,89	0,33
018	4,80	1,35	5,28	0,50
026	6,27	1,78	6,93	0,73
037	8,23	2,75	9,43	1,15
050	11,25	3,73	12,81	1,63
076	15,90	5,50	18,66	2,30
110	22,94	8,50	27,02	3,50
160	27,46	11,90	33,30	4,80
230	38,10	16,90	45,20	7,00
360	55,00	25,00	67,00	10,00
520	71,00	37,00	90,20	15,00
800	101,00	53,00	120,20	23,00
1200	/	93,00	/	38,00

* Weight with maximum number of springs

Tab. 13-4 Weight and volume of the rotary actuators

The bar products are comprehensively tested. The company bar therefore only guarantees the replacement or - at its sole discretion - the free repair of those components of the delivered products which, in the opinion of bar, have demonstrable manufacturing defects. Warranty claims due to defects or defects of title can be asserted within one (1) year from delivery/transfer of risk. Excluded from the warranty are damages due to normal product use or friction as well as damages due to changes or unauthorized repairs to the products for which bar rejects any claim for damages (direct or indirect). (Please refer to our website for detailed information.) All deliveries are subject to the General Conditions of Sale which can be found at www.bar-gmbh.de.

The descriptions and images contained in this product data sheet are for informational purposes only and are not guaranteed. bar GmbH reserves the right to make technical and constructive changes to its products without prior notice.

Warranty: All purchases and sales contracts expressly require the Purchaser to accept the General Terms and Conditions of Sale and Delivery which can be found on www.bar-gmbh.de/agb. bar GmbH hereby objects to any deviating or additional condition to the General Terms and Conditions of Sale and Delivery which has been communicated to the Purchaser in any form without the written consent of a representative of bar GmbH.

bar
A **WATTS** Brand

bar pneumatische Steuerungssysteme GmbH
Auf der Hohl 1 • 53547 Dattenberg • Germany
Tel. +49 (0)2644 96070 • Fax +49 (0)2644 960735
bar-info@wattswater.com • www.bar-gmbh.de