

2/2-way automatic valve

- **PKN** (with bar-acturn or actubar)
- **EKN**

Translation of the original operating manual

IMPORTANT: This manual is only valid in conjunction with the manufacturer documentation of the actuator



Table of Contents

1.	General information	5
1.1	Reference documents.....	5
1.2	Validity of the operating manual.....	5
1.3	Notes to operating manual	6
1.3.1	Signal words and symbols	6
1.3.2	Explanation of the structure of the safety instructions.....	7
1.3.3	Descriptions in figures.....	7
1.4	Responsibility of the operating company.....	7
2.	Safety	8
2.1	General Safety Instructions	8
2.2	Intended use.....	8
2.3	Reasonable foreseeable use	8
2.4	Organizational measures	8
2.4.1	Subsequent retrofitting or changes	8
2.4.2	Replacement of defective parts.....	8
2.5	Protective equipment.....	9
2.6	Personnel qualification	9
2.7	Dangers when handling the automatic valve.....	11
2.7.1	Dangers during assembly, maintenance and disassembly	11
2.7.2	Dangers during functional checks, commissioning and operation.....	14
2.7.3	Dangers when used in explosion-protected areas	15
3.	Product description	17
3.1	Kugelhahn	17
3.2	Rotary actuator	17
3.3	Type plate.....	18

4.	Transport, packaging and storage	19
4.1	Scope of delivery	19
4.2	Incoming goods inspection	19
4.3	Transport, packaging and storage	19
5.	Installation	21
5.1	Installation conditions	21
5.2	Before installation	21
5.3	Installation of ball valve	21
5.4	Mounting the rotary actuator	22
5.5	Pressure test of the pipe section	22
6.	Commissioning and operation	23
7.	Maintenance and repair	23
7.1	Maintenance of the actuator	23
7.2	Maintenance of ball valve	23
8.	Troubleshooting	23
9.	Repair and spare parts	24
10.	Disassembly	25
10.1	Disassembly of the actuator	25
10.2	Disassembly of the ball valve from the pipeline	25
11.	Disposal	25

12.	EU Declaration of Incorporation Type P...	26
13.	EU Declaration of Incorporation Type E...	27
14.	EU Declaration of Conformity Type E...	28
15.	ATEX Declaration of Conformity Type P...	29
16.	ATEX Declaration of Conformity Type E...	31
17.	Annex / Technical data	33
17.1	Technical data of rotary actuator	33
17.2	Technical data of 2/2-way ball valve of KN type	33
17.3	Pressure-Temperature diagram	34
17.4	Dimensional tables and dimensional drawings Type PKN with bar-agturn	35
17.4.1	Dimensional drawing Type PKN with bar-agturn	35
17.4.2	Dimensional table Type PKN with bar-agturn	36
17.4.3	Actuator assignment Type PKN with bar-agturn	38
17.5	Dimensional tables and dimensional drawings Type PKN with actubar	39
17.5.1	Dimensional drawing Type PKN with actubar	39
17.5.2	Dimensional table Type PKN with actubar	40
17.5.3	Actuator assignment Type PKN with actubar	42
17.6	Dimensional tables and dimensional drawings Type EKN	43
17.6.1	Dimensional drawing Type EKN	43
17.6.2	Dimensional table Type EKN	44

1. General information

This operating manual is a part of the product. The operating manual must be kept for the entire life of the product and must be passed on to each subsequent owner of the product.

The operating manual must always be available at the place of operation.

1.1 Reference documents

This manual, the data mentioned and design data sheets, additional assembly and maintenance instructions as well as further information – also in other language versions, can be obtained from:

bar pneumatische
Steuerungssysteme GmbH

Auf der Hohl 1
53547 Dattenberg

Tel.: +49 (0)2644-9607-0
Fax: +49 (0)2644-960735

Email: bar-info@wattswater.com
www.bar-gmbh.de

IMPORTANT

This manual is only valid in conjunction with the manufacturer documentation of the rotary actuator.

bar pneumatische Steuerungssysteme GmbH

Auf der Hohl 1
53547 Dattenberg

Tel.: +49 (0)2644-9607-0
Fax: +49 (0)2644-960735

Email: bar-info@wattswater.com
www.bar-gmbh.de

Valpes

Z.I. Centr'alp
89 rue des étangs
F - 38430 Moirans

Tel. +33 (0) 4 76 35 06 06
Fax +33 (0) 4 76 35 14 34

valpes-info@wattswater.com
www.valpes.com

1.2 Validity of the operating manual

This operating manual is valid for the 2/2-way automatic valve of PKN /EKN type since year of manufacture 2019 with one of the following rotary actuators:

bar-agturn

- agturn Type GD-032 till 040
- agturn Type GD/GS-052 till 400

actubar

- actubar Type AD-001
- actubar Type AD/AS-002 till 1200

Electric rotary actuator of company Valpes

1.3 Notes to operating manual

The safety and hazard statements in the document are intended for your protection, the protection of third parties and the protection of the product. The instructions must therefore be observed.

1.3.1 Signal words and symbols

DANGER

... indicates a hazard that, if not avoided, will result in death or serious injury.

WARNING

... indicates a hazard that, if not avoided, could result in death or serious injury.

CAUTION

... indicates a hazard which, if not avoided, could result in minor or moderate injury.

NOTE

... indicates important information (e.g. Material damage) but not hazards.



Electric voltage!

The text passages marked with this symbol inform you about dangerous situations with danger to life and health of persons due to electrical voltage.



Corrosive substances!

The text passages marked with this symbol inform you about dangerous situations caused by corrosive substances.



Hot surface!

The text passages marked with this symbol inform you about dangerous situations with a risk of burns due to hot surfaces.



Cold surface!

The text passages marked with this symbol inform you about dangerous situations with a risk due to cold surfaces.



Suspended load!

The text passages marked with this symbol inform you about dangerous situations with a risks due to suspended load.



Hand injuries!

The text passages marked with this symbol inform you about dangerous situations resulting in hand injuries caused by bruising or punching. The activities described in the relevant text passage must be performed with the utmost care to avoid dangerous situations and resulting injuries such as loss of limbs.



Use head protection!

Notes with this symbol indicate that a head protection must be worn.



Use protective clothing!

Notes with this symbol indicate that a protective clothing must be worn.



Use hand protection!

Notes with this symbol indicate that a hand protection must be worn.

1.3.2 Explanation of the structure of the safety instructions

A safety instruction is initiated with a signal word describing the severity of the danger („Chapter 1.3.1 Signal words and symbols“).

WARNING

Type or source of danger (possibly with warning signs according to DIN EN ISO 7010)

Consequences in case of not following the instruction

- Avoidance of danger

1.3.3 Descriptions in figures

The figures in this operating manual are intended to help you understand the facts and procedures.

The descriptions in the figures are exemplary and may differ slightly from the actual appearance of your product.

1.4 Responsibility of the operating company

- The installation, electrical and pneumatic connection as well as the commissioning of the product may only be carried out by qualified personnel in accordance with the instructions described in this operating manual.
- The product may only be operated and maintained by personnel of the legal minimum age and the corresponding personnel qualification.
- This operating manual is an integral part of the product and must be available to the personnel at all times. This operating manual must be read and understood before the first commissioning.
- The operating and technical personnel must be instructed about safety devices of the product as well as safe working methods.
- The product may only be operated in perfect condition. No safety devices may be removed or disconnected.

2. Safety

2.1 General Safety Instructions

Personnel assigned to work on the automatic valve must read the operating instructions before starting work and, in particular, understand the chapter "Safety" before starting work. This is particularly valid for personnel working only occasionally on the rotary actuator.

2.2 Intended use

- The automatic valve is used for the automatic shut-off of liquids and gases in pipelines.
- The automatic valve is designed for use in process engineering plants.
- The operating values, limit values and setting data specified in the operating manual and the corresponding data sheet must be observed.
- Intended use also includes the observance of these operating instructions.

2.3 Reasonable foreseeable use

Any use other than that described in „Chapter 2.2 Intended use“ and any use not approved by the manufacturer is considered as unintended.

DANGER

Danger of explosion!

The automatic valve in combination with an electric actuator is not intended for use in potentially explosive atmospheres as standard. For this purpose, an electric actuator suitable for ATEX applications must be selected.

- Do not use the automatic valve with standard E drive in potentially explosive atmospheres.

2.4 Organizational measures

2.4.1 Subsequent retrofitting or changes

The operator must make a corresponding assessment of the hazards when dealing with subsequently integrated components and retrofitting.

If you want to use a different medium or use the ball valve for a different purpose, contact our customer service. We can help you with any possible necessary configurations.

2.4.2 Replacement of defective parts

Replace parts of the rotary actuator that are not in perfect condition immediately with original spare parts.

Please note that only original spare and wear parts of bar GmbH are to be used.

In the case of usage of the third-party parts, it is not ensured that they are designed and manufactured to suit the requirements.

2.5 Protective equipment

If necessary, the protective equipment shall be used. Keep your hair and clothing away from moving parts. If necessary, wear a hairnet and do not wear jewellery such as necklaces and rings!



Use head protection!

Wear suitable head protection during transport.



Use protective clothing!

Wear suitable protective clothing during commissioning, maintenance and troubleshooting.



Use hand protection!

Wear suitable hand protection during transport, commissioning, maintenance and troubleshooting.

2.6 Personnel qualification

Only trained or instructed personnel who has known and understood the operating instructions as well as the possible dangers of the rotary actuator is allowed to work with the rotary actuator. The responsibility of the personnel for operation, maintenance and repair must be clearly defined by the operator.

Personnel to be trained, instructed or undergoing training may work on the rotary actuator only under the constant supervision of an experienced person.

The individual activities on the rotary actuator require different personnel qualifications which are listed in the following table. The different qualifications are characterized by the following skills and knowledge:

- Instructed persons must operate the rotary actuator and be able to detect possible damage and dangers on the rotary actuator.
- Instructed persons with technical training must also be aware of the dangers of handling pressurized equipment, hot and cold surfaces, harmful and hazardous materials and the process of installing and removing the valves in a process line, the specific and potential risks of the process and the most important safety regulations.
- Trained electricians must read and understand electrical circuit diagrams, commission, put electric machines into operation, service and maintain them, wire switch and control cabinets, install control software, ensure the functionality of electrical components and identify potential hazards in handling electrical and electronic systems.
- Trained pneumatic specialists must read and understand pneumatic circuit diagrams, put pneumatic systems into operation, service and maintain them, disconnect and connect pneumatic hoses, ensure the proper functioning of pneumatic components, assess the work performed on the pneumatic system and identify potential hazards.

Read this table as follows:

"The electrical installation requires the qualification of a qualified electrician."

Activities	Instructed persons	Instructed persons with technical training	Electricians	Pneumatic specialists
Installation		X		
Electrical installation			X	
Pneumatic installation				X
Setting and equipping		X		
Commissioning		X		
Troubleshooting	X			
Cleaning	X			
Troubleshooting, repair and maintenance of mechanics		X		
Troubleshooting, repair and maintenance of electrics			X	
Troubleshooting, repair and maintenance of pneumatics				X
Functional checks		X		
Shutdown	X		X	
Transport	X			
Disposal	X			

Tab. 2-1 Overview of the required personnel qualifications

2.7 Dangers when handling the automatic valve

This product of bar GmbH is built according to the state of the art and the recognized safety rules. Nevertheless, there remains a residual risk and may cause dangers to the life and limb of the user or third parties or impairments of the product and other material assets in use, if:

- the product is not used as intended,
- the product is operated or repaired by untrained personnel,
- the product is improperly changed or modified and/or
- the safety instructions are not observed.

Eliminate faults that may affect safety.

2.7.1 Dangers during assembly, maintenance and disassembly

DANGER



Electric voltage!

There is danger to life when working on electrical components.

- The electrical connections may be performed only by qualified electricians.
- When working on the components, have the voltage released by a qualified electrician and secured against being switched on again.
- Let a qualified electrician check that no current is present.

DANGER



Corrosive substances!

Depending on the type of medium, there may be danger to life when in contact with the medium.

- Check the properties of the medium.
- Protect yourself and your environment from harmful or toxic substances.
- Follow the safety instructions in the manufacturer's safety data sheets.
- Make sure that no medium can get into the pipeline, valves during assembly work.
- Make sure that personnel working with the valves and installing or repairing the valves have received appropriate training.

WARNING



Very cold and hot surfaces!

The body of the valve can become very cold or very hot during operation.



- Wear protective gloves and protective clothing to protect against frostbite or burns.
- Make sure that personnel working with the valves and installing or repairing the valves have received appropriate training.

⚠ WARNING



Danger of crushing hands and other body parts!

There is a risk of injury during assembly/disassembly by movements of the ball. The shut-off body (e.g. ball or disc) of the valve works as a separating element. It makes no difference whether a rotary actuator is mounted or not. The position of the ball may change during transport or handling of the valve.

- Keep hands and fingers away when power is connected.
- Always disconnect the power supply from the rotary actuator before carrying out maintenance and repair work on the valve and when installing and removing the ball valve from the pipeline.
- Pay attention to movements of the ball.
- Keep hands, other body parts, tools and other objects out of the swivel range of the ball. Do not leave any foreign objects inside the pipeline.
- Perform works carefully when assembling, disassembling and sampling.

⚠ WARNING

**Flying parts!
Splashing medium!**

There is a risk of injury when the valve is removed under pressure or with present medium. The disassembly or removal of a pressurised valve causes an uncontrolled pressure drop.

- Do not disassemble or remove the valve from the pipeline as long as the valve is pressurized.
- Always isolate the respective valve in the piping system.
- Depressurise the valve and remove the medium before working on the valve and the rotary actuator.

⚠ WARNING

**Ejected parts!
(only for pneumatic actuator)**

When adjusting the rotary actuators and when the rotary actuator is opened under pressure, there is a risk of parts being ejected!

- Always disconnect the compressed air supply before maintenance, disassembly and repair!
- Never set the mechanical end positions on the actuator as long as there is pressure on connection 2 or 4.
- Never dismount the threaded pins of the vacotrol interface under pressure (only for actubar).
- Make sure the pinion of the rotary actuator is moving in the correct direction.

WARNING

Uncontrolled start-ups! (only for pneumatic actuator)

There is a risk of injury if pneumatic rotary actuators create a very high torque during actuation or by spring force.

- Secure the rotary actuator against any unintentional start-up or unexpected spinning.
- Work on the pneumatic rotary actuators in a prudent way.
- In case of single-acting rotary actuators (type GS), make sure that the rotary actuator is in the home position (relaxed springs) when disassembling.

CAUTION

Hand injuries!

When mounting the rotary actuator on the valve spindle, the rotary actuator is pushed to the connection point/flange of the valve.

When disassembling the rotary actuator or removing the rotary actuator from the valve spindle, the parts can slip down.

There is danger of crushing the hands!

- Carefully pull off the rotary actuator.
- Keep fingers and hands away from the connection point.

NOTE

Material damage to valve spindle!

Material damage can occur if you use built-on rotary actuators as levers.

- Do not use built-on actuators as levers as they could damage the actuator and the valve.

2.7.2 Dangers during functional checks, commissioning and operation

DANGER

Bursting parts! Escaping media!

There is danger to life if the maximum permissible pressure and temperature ranges of the valve are insufficient for the operating conditions of the system. There is a risk of injury and the risk of material damage by wrongly selected materials.

In addition, there is a risk of damage to the piping system.

- Only use the valves that are designed for the operating conditions.
- Make sure that the selected materials of the parts of the valve coming in contact with the medium are suitable for the media used.

DANGER

Escaping medium!

 There is a risk of death from escaping medium as a result of leaks (scalding, hazardous substances).

- Protect yourself from thermal or chemical burns.
- Leave the danger area in case of leakage and keep third persons out of the danger zone. Use appropriate barriers or name supervisors.

WARNING

Danger of being pulled in, danger of crushing and locking!

Danger due to moving parts of the machine/valve which can be accessed through assembly, disassembly, removable covers at openings for functional checks, sampling, etc. and through automatically operated valves.

- Keep hands and fingers away when compressed air or power is connected.
- Please note that single-acting rotary actuators can move the valve to the "open" or "closed" position when closing or disconnecting the compressed air supply (only for pneumatic actuator).
- Perform works carefully when commissioning, making functional checks and sampling.

WARNING

Risk of burns!

 Devices and system components can become very hot during operation.

- Wear protective gloves and protective clothing to protect against burns.
- At operating temperatures > 65°C a short contact (approx. 1s) of the skin with the surface of the machine/valve may cause burns (DIN EN ISO 13732-1).

- At operating temperatures = 60 °C a long contact (approx. 3s) of the skin with the surface of the machine/valve may cause burns (DIN EN ISO 13732-1).
- At operating temperatures 55 °C – 60 °C a long contact (approx. 3S to 10s) of the skin with the surface of the machine/valve may cause burns (DIN EN ISO 13732-1).

CAUTION

Self-loosening components!

Components and fasteners may become loose if not properly installed.

- Observe the information on tightening torques in this operating manual.
- Check the tightening torque of screw connections and tighten with the torque wrench, if necessary.

CAUTION

Noise! (only for pneumatic actuator)

When venting the pneumatic rotary actuator, noise can be hazardous to health.

- Use silencer at vent port or take other personal protection measures.

2.7.3 Dangers when used in explosion-protected areas

DANGER

Danger of explosion!

An explosion can occur if the following protective measures are not observed:

- Establish an internal electrically conductive equipotential bonding between the rotary actuator and all metal mounting parts and the pipeline and make sure that sufficient lightning protection is available.
- Protect the surfaces against inadmissibly high temperatures due to solar radiation. Shading covers can possibly be required.
- Protect the actuator against excessive heating due to heat transfer with hot media inside the pipeline. If necessary, mounting kits or shaft extensions are required.
- Please be aware of that the max. surface temperature significantly depends on the operating conditions. Make sure that the actual max. surface temperature is not an ignition source.
- When selecting the pneumatic valves and the end position feedbacks, pay attention to the combination with Ex-approved products.
- Avoid sparking when using the tool.

 **DANGER**

Danger of explosion!

(continuation)

- Always observe the max. permissible operating pressure. Exceeding can cause material failure which can lead to sparking.
- Avoid dust accumulation.
- Do not install rotary actuators in pit-like cavities if there is a predictable dust accumulation.
- Do not carry out leak detection with ultrasonic transmitters.

3. Product description

The 2/2-way automatic valve of PKN/EKN type is a combination of the following components:

- 2/2-way ball valve of KN type made of stainless steel, two-part, with floating precision ball

and one of the following rotary actuators (according to order):

PKI (pneumatic)

- agturn Type GD-032 till 040 and Type GD/GS-052 till 400
- actubar Type AD-001 and Type AD/AS-002 till 1200

EKI (electric)

- electric rotary actuator of company Valpes

The valve is operated pneumatically (double- and single-acting) or electrically and is characterized by a long service life and high operational safety.

Product features:

- Full passage
- Maintenance-free
- Optionally available with end position feedback, position controllers and solenoid valves (only for pneumatic rotary actuators)
- Anti-blowout spindle
- Usage also with vacuum and high flow velocities
- Alternatively also can be delivered with hand lever or gearbox

3.1 Kugelhahn

The 2/2-way ball valve of KN type is intended for installation in piping systems. Its function is to shut off or regulate a medium in pipelines.

3.2 Rotary actuator

The rotary actuator is used for the automatic actuation of industrial valves continuously moving between the end positions.

3.3 Type plate

The type plate of the automatic valve is attached to the rotary actuator.



Fig. 3-1 Type plates PKN



Fig. 3-2 Type plate EKN

Legend

- 1 bar article number
- 2 Article/order designation (see data sheet)
- 3 Control pressure range for the pneum. rotary actuator
- 4 Maximum permissible medium pressure
- 5 Manufacture date (year of construction)
- 6 ATEX marking
- 7 Electric voltage
- 8 Protection type

4. Transport, packaging and storage

4.1 Scope of delivery

- 2/2-way automatic valve of PKN or EKN type
- Possibly ordered accessories

4.2 Incoming goods inspection

The following items must be checked at the time of delivery:

- Does the number of delivered transport containers correspond to the delivery note?
- Is the packaging free of visible damage?
- Are the product and accessories free of visible damages?
- Are there any evidences of not gentle handling during the transport (e.g., burns, scratches, colour)?

To have all the right for claim against the transport company, you have to document the possible external transport damages (e.g. with photographs and a written protocol) before unpacking the product.

bar GmbH is not responsible for transport damages and can take over no liability for that.

4.3 Transport, packaging and storage

DANGER



Suspended load!

When transporting, e.g. with a crane, there is a risk that parts fall down and people are seriously injured.

- Never exceed the permissible load of the hoisting equipment used.
- Use only suitable, approved and undamaged lifting slings for transport.
- If you attach lifting slings to the rotary actuator, they must be designed for the entire actuator.
- Connect the slings so that the products can not be damaged.
- Exercise the utmost care when handling and balancing the load.
- Perform the works with constant eye contact with the load.
- Do not stay under or near the lifted load.
- Keep third persons out of the danger zone. Use appropriate barriers or name supervisors.

NOTE

Lifting slings are factory-fitted for dimensions with high weights. They are designed exclusively for the weight of the actuator and must not be used for lifting the automatic valve!

The products must be handled, transported and stored with care:

- There is no liability of the manufacturer for transport within the customer's territory or to the individual places of use.
- The products should be transported in their original packaging or on a pallet (or similarly supported) to the installation site and unpacked immediately before installation.
- When storing before installation, keep the products in a closed room and protect them from harmful influences such as dirt or moisture.
- The products must be stored in their original packaging and, if necessary, with the appropriate protective covers.
- In case of a longer storage period, the pneumatic rotary actuator must be operated at least once a year.
- Proper disposal of the packaging is the responsibility of the customer.

5. Installation

⚠ WARNING

Installation works

There is a risk of injury if this product is not properly installed, disassembled and put into operation.

- Make sure the personnel has received the appropriate training.
- Observe the safety instructions in „Chapter 2. Safety“.

NOTE

Check the technical parameters, in particular pressure and temperature, and the electrical voltage of the control valve before installing or commissioning the actuator.

The piping system and control system must be installed properly.

Make sure the valve is moving in the correct direction of rotation. Always mount the valves into the pipeline without tensing them.

The valve is not designed to absorb additional pipe connection forces. In the case of large valves, it is recommended to support the pipeline.

5.1 Installation conditions

The minimum space requirement can be found in the dimension drawing or dimension table („Chapter 17. Annex / Technical data“).

5.2 Before installation

Observe the following points before installation:

- The dew point of the control medium must be min. 10 °C lower than the lowest operating temperature! The max. temperature of the control medium is 45 °C!

For other valve types, in particular large-volume valves with low torque requirement, the operating conditions of the actuator must be agreed with the manufacturer. We will be delighted to advise you.

5.3 Installation of ball valve

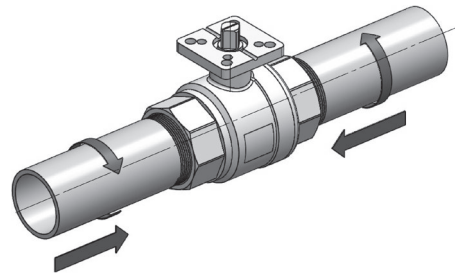

Fig. 5-1 Mounting a ball valve in pipeline

1. Before applying additional sealing materials, test whether the pipeline can easily be screwed into the valve body.
2. Apply suitable sealing material to the pipeline ends. By using PTFE-ribbon or hemp sealings observe the screw direction. Do not use sealing material that is not suitable for your intended purpose.
3. Screw the pipelines into the threaded ends of the ball valve. Do not use the complete valve as a lever.

4. Attention! Before you pressurize the pipeline, the sealing material must be hardened. Information on the hardening time is available from the respective manufacturer.
5. Check all connections for leaks.
6. Check all screwed connections and mounting parts for tightness.

5.4 Mounting the rotary actuator

For information on mounting the actuator, refer to the manufacturer documentation supplied with the actuator (by bar GmbH for PKN and by Valpes for EKN).

5.5 Pressure test of the pipe section

The following must be observed when making the pressure test of a pipe section with installed valves:

Carefully rinse newly installed piping systems to flush out any foreign objects.

Valve opened:

- The test pressure must not exceed the value of $1.5 \times PN$ as marked on the housing.

Valve closed:

- The test pressure must not exceed the value of $1.1 \times PN$ as marked on the housing.

6. Commissioning and operation

For information on commissioning and operation of the actuator, refer to the manufacturer documentation supplied with the actuator.

7. Maintenance and repair

The automatic valve is a maintenance-free device.

In terms of operational safety, however, it is recommended to check them for function and to switch at least every three months but no later than after 50,000 switching cycles; and in case of difficult operating conditions even more often.

Do not use harsh detergents or abrasives to clean the housings.

7.1 Maintenance of the actuator

For information on maintenance of the actuator, refer to the manufacturer documentation supplied with the actuator.

7.2 Maintenance of ball valve

Repair and maintenance of the seal and wear parts of the butterfly valve must not be carried out because it is about high-pressure glued ball valve.

NOTE

We recommend that you have the repair carried out by the company bar GmbH. We will be pleased to offer you a corresponding servicing, maintenance or repair. Please contact the company bar GmbH for this.

8. Troubleshooting

WARNING

Observe the safety instructions

There is danger to life if you do not observe safety instructions.

- When eliminating the faults, always observe the safety instructions from „Chapter 8. Troubleshooting“.

NOTE

Spare parts are to be ordered with all information on the type plate and the serial number. It is allowed to mount only original parts of bar GmbH.

9. Repair and spare parts

For information on repairing the actuator, refer to the manufacturer documentation supplied with the actuator.

10. Disassembly

DANGER



Electric voltage!

There is danger to life when working on electrical components.

- Work on electrical connections should only be carried out by qualified electricians with the supply voltage switched off and secured against reconnection.

WARNING

Installation works

There is a risk of injury if this product is not properly installed, disassembled and put into operation.

- Make sure the personnel has received the appropriate training.
- Observe the safety instructions in „Chapter 2. Safety“.

10.1 Disassembly of the actuator

For information on disassembling the actuator, refer to the manufacturer documentation supplied with the actuator.

10.2 Disassembly of the ball valve from the pipeline

If the unit is to be replaced by a structurally identical one, it is necessary to loosen the pipe ends of the thread of the ball valve and then remove it.

11. Disposal

- Proper disposal of the products is the responsibility of the customer. Dispose of the products after their use in accordance with the legal requirements regarding safety and environmental protection.
- The materials used in the products are steel, aluminum, brass, copper and various plastics.

Dispose of lubricated parts separately according to local environmental regulations!

If you have any questions, please contact the company bar GmbH.

12. EU Declaration of Incorporation Type P...



A WATTS Brand

Auf der Hohl 1 | 53547 Dattenberg | Germany | T: +49 (0)2644 9607-0 | F: +49 (0)2644 9607-35

Z5100001_00B

Einbauerklärung für eine unvollständige Maschine / Declaration of Incorporation of a partly completed machinery

im Sinne der Maschinenrichtlinie 2006/42/EG, Anhang II Teil 1B /
according to Machinery Directive 2006/42/EC, Annex II 1b
(EU-Abt. L 157/24 vom 09.06.2006)

Name und Anschrift des Herstellers: **bar pneumatische Steuerungssysteme GmbH**
Name and address of the manufacturer: **Auf der Hohl 1, 53547 Dattenberg / Germany**

Diese Erklärung bezieht sich nur auf das Produkt in dem Zustand, in dem es in den Verkehr gebracht wurde.
Die Erklärung verliert ihre Gültigkeit, wenn das Produkt ohne Rücksprache mit uns umgebaut oder verändert wird.

*This declaration relates exclusively to the product in the state in which it was placed on the market.
The declaration loses validity if the product is modified without agreement of company bar.*

Hiermit erklären wir, dass die nachstehend beschriebenen Produkte
Herewith we declare that the following products

Produktbezeichnung: **Automatik-Armatur mit pneumatischem Stellantrieb**
Product denomination: **Automatic-valve with pneumatic actuator**
Serien-/Typenbezeichnung / model/type: **PKO..., PKO2..., PKL..., PKN..., PKW..., PMK..., PMK2...,
PKT..., PZDS..., PZR...**

unvollständige Maschinen im Sinne der Maschinenrichtlinie sind und die folgenden grundlegenden Anforderungen der
Richtlinie 2006/42/EG erfüllen:
are partly completed machinery according to the Machinery Directive and meet the following basic requirements of the
directive 2006/42/EC:

Anhang I, Ziffern / Annex I, articles: 1.1.3, 1.1.5, 1.3.2, 1.3.4, 1.3.7, 1.3.9, 1.5.3, 1.5.4, 1.5.5, 1.5.8, 1.7.3, 1.7.4

Die bar-Automatik-Armatur mit pneumatischem Schwenkantrieb ist ausschließlich zum Einbau in eine Rohrleitung bestimmt.
Die Inbetriebnahme ist solange untersagt, bis sichergestellt wurde, dass die gesamte Maschine, in die das Produkt
eingebaut ist, den Bestimmungen der EG-Richtlinie 2006/42/EG in vollem Umfang entspricht.

*bar automatic-valves with pneumatic actuators are designed to be installed into a pipework. The product must not put in
service until the final machinery into which they are to be incorporated has been declared in conformity with the provisions of
the Directive 2006/42/EC.*

Der Hersteller verpflichtet sich, die Unterlagen zur unvollständigen Maschine der zuständigen nationalen Behörde auf
Verlangen elektronisch zu übermitteln. Die zur Maschine gehörenden speziellen technischen Unterlagen nach Anhang VII
Teil B wurden erstellt.

*With regard to the partly completed machinery, the manufacturer commits to submitting the documents to the competent
national authority via electronic transmission upon request. The relevant technical documentation pertaining to the
machinery described in Annex VII, part B has been prepared.*

Die Einhaltung der in den technischen Daten und Sicherheitshinweisen beschriebenen Betriebsbedingungen ist
sicherzustellen. Please take care about the technical data and the relevant warning and safety notices.

Bevollmächtigter für die Dokumentation: **Klaus Scholl,**
Authorised person for documentation: **Auf der Hohl 1,
D-53547 Dattenberg**

Dattenberg, 21.12.2021
Ort, Datum
Place, Date

Repellin, Lionel, Operations Manager
Name, Vorname und Funktion des Unterzeichners
Surname, first name and function of signatory

Unterschrift
Signature



Management
System
ISO 9001:2015



Deutsche Bank Neustadt Weinstraße • SWIFT DEUTDE33 • IBAN DE35 5467 0095 0022 8114 00
Deutsche Bank Amsterdam • SWIFT DEUTNL33 • IBAN NL52 0319 8666 53
HRB 10991 Amtsgericht Montabaur • USt-Nr. DE 149 622 999
Geschäftsführer: Olivier Gverdon, Nigel Wood
bar-info@wattswater.com

bar-gmbh.de

13. EU Declaration of Incorporation Type E...



Z5100004_00A

A WATTS Brand

Auf der Hohl 1 | 53547 Dattenberg | Germany | T: +49 (0)2644 9607-0 | F: +49 (0)2644 9607-35

Einbauerklärung für eine unvollständige Maschine / Declaration of Incorporation of a partly completed machinery

im Sinne der Maschinenrichtlinie 2006/42/EG, Anhang II Teil 1B /
according to Machinery Directive 2006/42/EC, Annex II 1b
(EU-Abt. L 157/24 vom 09.06.2006)

Name und Anschrift des Herstellers: **bar pneumatische Steuerungssysteme GmbH**
Name and address of the manufacturer: **Auf der Hohl 1, 53547 Dattenberg / Germany**

Diese Erklärung bezieht sich nur auf das Produkt in dem Zustand, in dem es in den Verkehr gebracht wurde.
Die Erklärung verliert ihre Gültigkeit, wenn das Produkt ohne Rücksprache mit uns umgebaut oder verändert wird.

*This declaration relates exclusively to the product in the state in which it was placed on the market.
The declaration loses validity if the product is modified without agreement of company bar.*

Hiermit erklären wir, dass die nachstehend beschriebenen Produkte
Herewith we declare that the following products

Produktbezeichnung: Product denomination:	Automatik-Armatur mit elektrischem Stellantrieb Automatic-valve with electric actuator
Serien-/Typenbezeichnung / model/type:	EK1..., EKN..., EKO..., EKO2..., EKW..., EMK..., EMK2..., EKT..., EZDS..., EZR...

unvollständige Maschinen im Sinne der Maschinenrichtlinie sind und die folgenden grundlegenden Anforderungen der Richtlinie 2006/42/EG erfüllen:
are partly completed machinery according to the Machinery Directive and meet the following basic requirements of the directive 2006/42/EC:

Anhang I, Ziffern / Annex I, articles: 1.1.3, 1.1.5, 1.3.2, 1.3.4, 1.3.7, 1.3.9, 1.5.3, 1.5.4, 1.5.5, 1.5.8, 1.7.3, 1.7.4

Die bar-Automatik-Armatur mit pneumatischem Schwenkantrieb ist ausschließlich zum Einbau in eine Rohrleitung bestimmt.
Die Inbetriebnahme ist so lange untersagt, bis sichergestellt wurde, dass die gesamte Maschine, in die das Produkt eingebaut ist, den Bestimmungen der EG-Richtlinie 2006/42/EG in vollem Umfang entspricht.

bar automatic-valves with pneumatic actuators are designed to be installed into a pipework. The product must not put in service until the final machinery into which they are to be incorporated has been declared in conformity with the provisions of the Directive 2006/42/EC.

Der Hersteller verpflichtet sich, die Unterlagen zur unvollständigen Maschine der zuständigen nationalen Behörde auf Verlangen elektronisch zu übermitteln. Die zur Maschine gehörenden speziellen technischen Unterlagen nach Anhang VII Teil B wurden erstellt.

With regard to the partly completed machinery, the manufacturer commits to submitting the documents to the competent national authority via electronic transmission upon request. The relevant technical documentation pertaining to the machinery described in Annex VII, part B has been prepared.

Bevollmächtigter für die Dokumentation/ Authorised person for documentation:	Klaus Scholl, Auf der Hohl 1, D-53547 Dattenberg
---	--

Die Einhaltung der in den technischen Daten und Sicherheitshinweisen beschriebenen Betriebsbedingungen ist sicherzustellen. *Please take care about the technical data and the relevant warning and safety notices.*

Dattenberg, 21.12.2021
Ort, Datum
Place, Date

Repellin, Lionel, Operations Manager
Name, Vorname und Funktion des Unterzeichners
Surname, first name and function of signatory

Unterschrift
Signature



Deutsche Bank Neustadt Weinstraße • SWIFT DEUTDE33 • IBAN DE35 160 0095 0022 8114 00
Deutsche Bank Amsterdam • SWIFT DEUTNL2N • IBAN NL52 DEUT 0319 8666 53
HRB 10991 Amtsgericht Montabaur • Ust-Nr. DE 149 522 999
Geschäftsführer: Olivier Giverdon, Nigel Wood
bar-info@wattswater.com

bar-gmbh.de

14. EU Declaration of Conformity Type E...



Z5100005_00A

A WATTS Brand

Auf der Hohl 1 | 53547 Dattenberg | Germany | T: +49 (0)2644 9607-0 | F: +49 (0)2644 9607-35

EU Konformitätserklärung EU Declaration of Conformity

Name und Anschrift des Herstellers: **bar pneumatische Steuerungssysteme GmbH**
Name and address of the manufacturer: **Auf der Hohl 1, 53547 Dattenberg / Germany**

Diese Erklärung bezieht sich nur auf das Produkt in dem Zustand, in dem es in den Verkehr gebracht wurde. Die Erklärung verliert ihre Gültigkeit, wenn das Produkt ohne Rücksprache mit uns umgebaut oder verändert wird.

This declaration relates exclusively to the product in the state in which it was placed on the market. The declaration loses validity if the product is modified without agreement of company bar.

Hiermit erklären wir, dass die nachstehend beschriebenen Produkte
Herewith we declare that the following products

Produktbezeichnung: **Automatik-Armatur mit elektrischem Stellantrieb**
Product denomination: **Automatic-valve with electric actuator**
Serien-/Typenbezeichnung / model/type: **EKI..., EKN..., EKO..., EKW..., EMK..., EMK2..., EKT..., EZDS..., EZR...**

nach den Anforderungen folgender Richtlinien hergestellt wurde
was manufactured according to the following directives:

2014/35/EU Niederspannungsrichtlinie / Low voltage directive
(EU-Abl. L 96/357 vom 29.03.2014)

2011/65/EU Beschränkung bestimmter gefährlicher Stoffe / Restriction of certain hazardous substances (RoHS)
(EU-Abl. L 174/88 vom 01.07.2011)

2014/53/EU Funkanlagenrichtlinie / Radio Equipment Directive (RED)
(EU-Abl. L 153/62 vom 22.5.2014)

2014/68/EU Druckgeräterichtlinie / Pressure Equipment Directive (PED)
(EU-Abl. L 189/164 vom 27.6.2014)

und den wesentlichen Anforderungen der Richtlinie 2014/30/EU Elektromagnetische Verträglichkeit (EMV; EU-Abl. L 96/79 vom 29.03.2014) entspricht.
and meets the essential requirements of the directive 2014/30/EU electromagnetic compatibility (EMC).

Die Einhaltung der in den technischen Daten und Sicherheitshinweisen beschriebenen Betriebsbedingungen ist sicherzustellen.
Please take care about the technical data and the relevant warning and safety notices.

Bevollmächtigter für die Dokumentation/
Authorised person for documentation:

Klaus Scholl,
Auf der Hohl 1,
D-53547 Dattenberg

Dattenberg, 21.12.2021
Ort, Datum
Place, Date

Repellin, Lionel, Operations Manager
Name, Vorname und Funktion des Unterzeichners
Surname, first name and function of signatory

Unterschrift
Signature



Deutsche Bank Neustadt Weinstraße • SWIFT DEUTDE33M546 • IBAN DE35 5467 0095 0022 8114 00
Deutsche Bank Amsterdam • SWIFT DEUTNL2N • IBAN NL52 DEUT 0319 8666 53
HRB 10991 Amtsgericht Montabaur • Ust-Nr. DE 149 522 999
Geschäftsführer: Olivier Giverdon, Nigel Wood
bar-info@wattswater.com

bar-gmbh.de

15. ATEX Declaration of Conformity Type P...



bar 19.0003

Z5100002_00B

A WATTS Brand

Auf der Hohl 1 | 53547 Dattenberg | Germany | T: +49 (0)2644 9607-0 | F: +49 (0)2644 9607-35

ATEX-Konformitätserklärung / ATEX Declaration of Conformity

Name und Anschrift des Herstellers: **bar pneumatische Steuerungssysteme GmbH**
Name and address of the manufacturer: **Auf der Hohl 1, 53547 Dattenberg / Germany**

Diese Erklärung bezieht sich nur auf das Produkt in dem Zustand, in dem es in den Verkehr gebracht wurde.
Die Erklärung verliert ihre Gültigkeit, wenn das Produkt ohne Rücksprache mit uns umgebaut oder verändert wird.
*This declaration relates exclusively to the product in the state in which it was placed on the market.
The declaration loses validity, if the product is modified without agreement of company bar.*

Hiermit erklären wir, dass das nachstehend beschriebene Produkt
Herewith we declare, that the following product

Produktbezeichnung: **Automatik-Armatur mit pneumatischem Stellantrieb**
Product denomination: **Automatic-valve with pneumatic actuator**
Serien-/Typenbezeichnung / model/type: **PKI...-ATEX...
PKN...-ATEX...
PKW...-ATEX...
PKT...-ATEX...**

nach den Anforderungen folgender Richtlinien hergestellt wurde:
was manufactured according to the following directives:

2014/34/EU ATEX-Richtlinie / ATEX – directive (EU-Abt. L 96/309 vom 29.03.2014)

Die Einhaltung der in den technischen Daten und Sicherheitshinweisen beschriebenen Betriebsbedingungen ist sicherzustellen. Der anlagenseitige elektrische Potentialausgleich der Anbauteile ist zu prüfen und über die gesamte Einsatzzeit sicherzustellen.
*Please take care about the technical data and the relevant warning and safety notices.
Check the electrical equipotential bonding of all parts and ensure it during whole operating time.*

Gerätekennzeichnung / Designation:  II 2 G Ex h IIC T6..T3 Gb
II 2 D Ex h IIIC T180°C Db

Für die max. Oberflächentemperatur in Abhängigkeit der Medien- und Umgebungstemperatur bitte Anhang I beachten!

Angewandte harmonisierte Normen: *Where appropriate harmonised Standards used:*

DIN EN ISO 80079-36:2016 Explosionsfähige Atmosphären – *Explosive atmospheres*
Teil 36: Nicht-elektrische Geräte für den Einsatz in explosionsfähigen Atmosphären – Grundlagen und Anforderungen
Part 36: *Non-electrical equipment for explosive atmospheres – Basic method and requirements*
DIN EN ISO 80079-37:2016 Explosionsfähige Atmosphären – *Explosive atmospheres*
Teil 37: Nicht-elektrische Geräte für den Einsatz in explosionsfähigen Atmosphären – Schutz durch konstruktive Sicherheit
"c" [...] *Part 37: Non-electrical equipment for explosive atmospheres – Non-electrical type of protection constructional safety "c"*

Dattenberg, 19.03.2020
Ort, Datum
Place, Date

Wood, Nigel, Managing Director
Name, Vorname und Funktion des Unterzeichners
Surname, first name and function of signatory

Unterschrift
Signature



Deutsche Bank Neustadt Weinstraße • SWIFT DEUTDE5546 • IBAN DE35 5467 0095 0022 8114 00
Deutsche Bank Amsterdam • SWIFT DEUTNL2N • IBAN NL52 DEUT 0319 8666 53
HRB 10991 Amtsgericht Montabaur • Ust-Nr. DE 149 522 999
Geschäftsführer: Olivier Giverdon, Nigel Wood
bar-info@wattswater.com

bar-gmbh.de

Anhang I
/ Annex I

Die maximal auftretenden Oberflächentemperaturen sind abhängig von den Betriebsbedingungen. Bitte entnehmen sie die jeweiligen Grenzwerte der entsprechenden Tabelle. Beachten Sie hierbei, dass die maximale Oberflächentemperatur sich nach dem höheren Wert (Medientemperatur innerhalb der Rohrleitung oder Umgebungstemperatur richtet).

The maximal occuring surface temperatures are depending on the working conditions. The respective temperature limits for ambient and media temperature can be found in the tables below. Please note, that the maximal occuring surface temperature is based on the higher (ambient or media within pipeline) temperature.

Umgebungstemperatur / Ambient temperature		
Maximal auftretende Oberflächentemperatur Maximal occuring surface temperature		Maximal zulässige Umgebungstemperatur Maximal permissible ambient temperature
T6	<85°C	65°C
T5	<100°C	80°C
T4	<135°C	115°C
T3	<200°C	160°C

Max. Umgebungstemperatur für / Max. ambient temperature for
 Antriebe in Standardausführung / actuators in standard version: 80°C
 Antriebe mit FKM-Dichtungen / actuators with FKM sealings: 120°C
 Antriebe in Hochtemperaturlausführung / high temperature version: 160°C

Medientemperatur innerhalb der Rohrleitung / media temperature within pipeline		
Maximal auftretende Oberflächentemperatur Maximal occuring surface temperature		Maximal zulässige Medientemperatur Maximal permissible media temperature
T6	<85°C	65°C
T5	<100°C	80°C
T4	<135°C	115°C
T3	<200°C	180°C

ACHTUNG: Es muss durch den Anlagenbetreiber sichergestellt werden, dass keine zusätzliche Erwärmung der Komponenten durch äußere Energiequellen (Strahlung etc.) stattfindet, um eine unzulässige Erwärmung der Komponenten zu vermeiden.

ATTENTION: The plant operator has to ensure that no additional heating of the components by external energy sources (e.g. radiation or emission etc.) takes place in order to avoid inadmissible heating of the components.



Deutsche Bank Neustadt Weinstraße • SWIFT DEUTDE5546 • IBAN DE35 5467 0095 0022 8114 00
 Deutsche Bank Amsterdam • SWIFT DEUTNL2N • IBAN NL52 DEUT 0319 8666 53
 HRB 10991 Amtsgericht Montabaur • Ust-Nr. DE 149 522 999
 Geschäftsführer: Olivier Giverdon, Nigel Wood
 bar-info@wattswater.com

16. ATEX Declaration of Conformity Type E...



bar 19.0005

Z5100007_00A

A WATTS Brand

Auf der Hohl 1 | 53547 Dattenberg | Germany | T: +49 (0)2644 9607-0 | F: +49 (0)2644 9607-35

ATEX-Konformitätserklärung / ATEX Declaration of Conformity

Name und Anschrift des Herstellers: **bar pneumatische Steuerungssysteme GmbH**
Name and address of the manufacturer: **Auf der Hohl 1, 53547 Dattenberg / Germany**

Diese Erklärung bezieht sich nur auf das Produkt in dem Zustand, in dem es in den Verkehr gebracht wurde. Die Erklärung verliert ihre Gültigkeit, wenn das Produkt ohne Rücksprache mit uns umgebaut oder verändert wird.
This declaration relates exclusively to the product in the state in which it was placed on the market. The declaration loses validity, if the product is modified without agreement of company bar.

Hiermit erklären wir, dass das nachstehend beschriebene Produkt
Herewith we declare, that the following product

Produktbezeichnung: **Automatik-Armatur mit elektrischem Stellantrieb**
Product denomination: **Automatic-valve with electric actuator**
Serien-/Typenbezeichnung / model/type: **EKI-...-ATEX..., EKN-...-ATEX..., EKW-...-ATEX...
EKT-...-ATEX...**

nach den Anforderungen folgender Richtlinien hergestellt wurde:
was manufactured according to the following directives:

2014/34/EU ATEX-Richtlinie / ATEX – directive (EU-Abt. L 96/309 vom 29.03.2014)

Die Einhaltung der in den technischen Daten und Sicherheitshinweisen beschriebenen Betriebsbedingungen ist sicherzustellen. Der anlagenseitige elektrische Potentialausgleich der Anbauteile ist zu prüfen und über die gesamte Einsatzzeit sicherzustellen.
Please take care about the technical data and the relevant warning and safety notices. Check the electrical equipotential bonding of all parts and ensure it during whole operating time.

Gerätekenzeichnung / Designation:

	Standardmodelle	II 2 G D	Ex db IIB T6 Gb	Ex tb IIIC T80°C Db	T _a = -20 °C bis +70 °C
	400 V Modelle	II 2 G D	Ex db IIB T5 Gb	Ex tb IIIC T95°C Db	T _a = -20 °C bis +54 °C
	BBPR Modelle	II 2 G D	Ex db IIB T6 Gb	Ex tb IIIC T80°C Db	T _a = -10 °C bis +40 °C

Für die max. Oberflächentemperatur in Abhängigkeit der Medientemperatur bitte Anhang I beachten!
For max media temperature within pipeline see annex I.

Angewandte harmonisierte Normen: *Where appropriate harmonised standards used:*

EN IEC 60079-0:2018 EN 60079-1:2014 EN 60079-31:2014

Die elektrischen Anschlüsse müssen die geltenden Empfehlungen der ATEX einhalten (Bedingungen BE3 der NF C-15100 und EN60079-14).
The electric connecting has to respect current ATEX recommendations (BE3 conditions of NF C-15100 and EN 60079-14).

Die mit der Qualitätssicherung der Produktion der elektrischen Antriebe beauftragte Einrichtung ist die
The notified body in charge of the production of the electric actuators quality surveillance is

LCIE (N°0081) : LCIE 15 ATEX Q 4009
33 av. du Général Leclerc PB 8, 92266 Fontenay-aux-Roses cedex, France.

Dattenberg, 21.12.2021
Ort, Datum
Place, Date

Repellin, Lionel, Operations Manager
Name, Vorname und Funktion des Unterzeichners
Surname, first name and function of signatory

Unterschrift
Signatur



Deutsche Bank Neustadt Weinstraße • SWIFT DEUTDE33M546 • IBAN DE35 8467 0095 0022 8114 00
Deutsche Bank Amsterdam • SWIFT DEUTNL33 • IBAN NL52 DEUT 0319 8666 53
HRB 10991 Amtsgericht Montabaur • Ust-Nr. DE 149 522 999
Geschäftsführer: Olivier Givardon, Nigel Wood
bar-info@wattswater.com

bar-gmbh.de

Anhang I
/ Annex I

Die maximal auftretenden Oberflächentemperaturen sind abhängig von den Betriebsbedingungen. Bitte entnehmen sie die jeweiligen Grenzwerte der entsprechenden Tabelle. Beachten Sie hierbei, dass die maximale Oberflächentemperatur sich nach dem höheren Wert (Medientemperatur innerhalb der Rohrleitung oder Umgebungstemperatur richtet).

The maximal occurring surface temperatures are depending on the working conditions. The respective temperature limits for ambient and media temperature can be found in the tables below. Please note, that the maximal occurring surface temperature is based on the higher (ambient or media within pipeline) temperature.

Medientemperatur innerhalb der Rohrleitung / media temperature within pipeline		
Maximal auftretende Oberflächentemperatur Maximal occurring surface temperature		Maximal zulässige Medientemperatur Maximal permissible media temperature
T6	<85°C	65°C
T5	<100°C	80°C
T4	<135°C	115°C
T3	<200°C	180°C

ACHTUNG: Es muss durch den Anlagenbetreiber sichergestellt werden, dass keine zusätzliche Erwärmung der Komponenten durch äußere Energiequellen (Strahlung etc.) stattfindet, um eine unzulässige Erwärmung der Komponenten zu vermeiden.

ATTENTION: The plant operator has to ensure that no additional heating of the components by external energy sources (e.g. radiation or emission etc.) takes place in order to avoid inadmissible heating of the components.



Deutsche Bank Neustadt Weinstraße • SWIFT DEUTDE33 • IBAN DE35 5467 0095 0022 8114 00
 Deutsche Bank Amsterdam • SWIFT DEUTNL2N • IBAN NL52 DEUT 0319 8666 53
 HRB 10991 Amtsgericht Montabaur • Ust-Nr. DE 149 522 999
 Geschäftsführer: Olivier Giverdon, Nigel Wood
 bar-info@wattswater.com

17. Annex / Technical data

17.1 Technical data of rotary actuator

The technical data of the rotary actuator can be found in the supplied manufacturer documentation.

17.2 Technical data of 2/2-way ball valve of KN type

	Standard design	Upon request
Nominal size	DN15 - DN50	
Connection type	Inside thread Rp 1/2" - Rp 2" acc. to ISO 7-1	
Mounting position	any	
Nominal pressure rating	PN100	
Operating pressure	See Pressure-Temperature diagram (see Chap. 17.3)	
Temperature range	-20 °C - 180 °C	
Materials	Housing: Stainless steel AISI 316 (1.4408) Ball: Stainless steel AISI 316 (1.4401) Switching shaft: Stainless steel AISI 316 (1.4401) Sealing bowl: PTFE Switching shaft seal: PTFE+ FKM	
Flow media	Neutral gases and liquids	Other media on request
Flow direction	any	

Tab. 14-1 Technical data of 2/2-way ball valve of KN type

17.3 Pressure-Temperature diagram

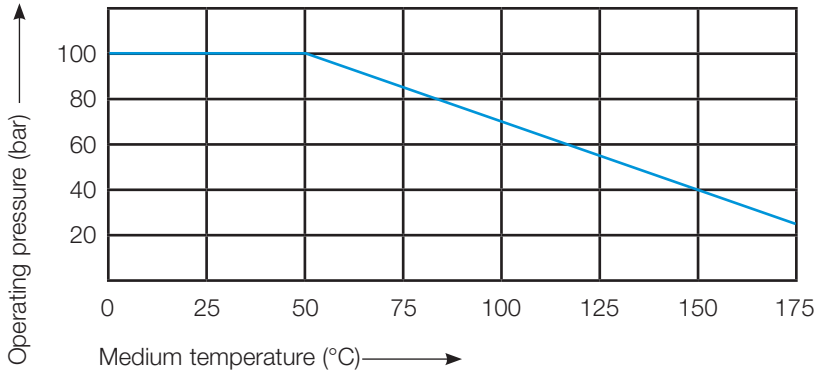

Tab. 14-2 Pressure-Temperature diagram

17.4 Dimensional tables and dimensional drawings Type PKN with bar- agturn

17.4.1 Dimensional drawing Type PKN with bar-agturn

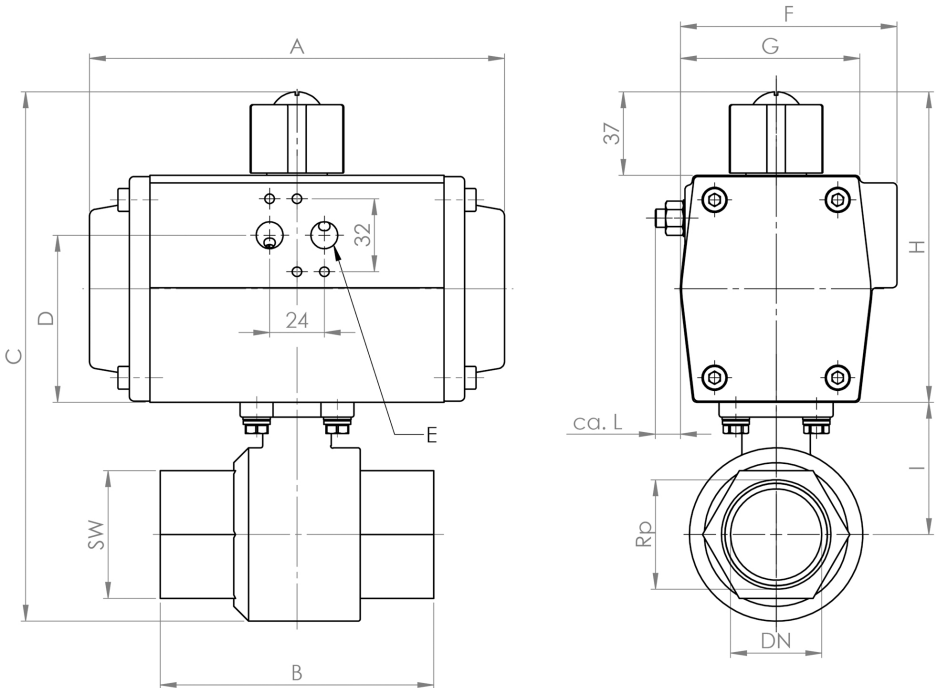

Fig. 13-1 Dimensional drawing Type PKN with bar-agturn type GD-075 (exemplary presentation)

17.4.2 Dimensional table Type PKN with bar-agturn

Thread „Rp“	DN	Actuator size	A	B	C	D	E
1/2"	15	040	120	60	150	24	G 1/4"
		052	147		162	48	G 1/4"
		063	165		182	61	G 1/4"
3/4"	20	052	147	70	170	48	G 1/4"
		063	165		190	61	G 1/4"
		075	182		201	73	G 1/4"
1/0"	25	052	147	90	179	48	G 1/4"
		063	165		195	61	G 1/4"
		075	182		207	73	G 1/4"
		083	208		216	80	G 1/4"
5/4"	32	063	165	110	208	61	G 1/4"
		075	182		220	73	G 1/4"
		083	208		229	80	G 1/4"
		092	262		237	91	G 1/4"
3/2"	40	075	182	120	233	73	G 1/4"
		083	208		242	80	G 1/4"
		092	262		250	91	G 1/4"
		105	270		271	99,5	G 1/4"
2/0"	50	075	182	140	253	73	G 1/4"
		083	208		262	80	G 1/4"
		105	270		386	99,5	G 1/4"
		125	301		308	127	G 1/4"

Tab. 13-3 Dimensional table Type PKN with bar-agturn, size A to E

Thread „Rp“	F	G	H	I	L	SW	Weight (kg)
1/2"	/	60.5	60	36	15	26	1,22
	74,5	60	72		9		1,62
	83	72	88		12		2,32
3/4"	74,5	60	72	39.5	9	32	1,76
	83	72	88		12		2,46
	95	84	99,5		11		3,01
1/0"	74,5	60	72	44	9	41	2,14
	83	72	88		12		2,84
	95	84	99.5		11		3,39
	103	92	109		12		4,09
5/4"	83	72	88	51	12	50	3,32
	95	84	99,5		11		3,87
	103	92	109		12		4,57
	109,5	102	116,5		9		6,56
3/2"	95	84	99,5	58	11	56	4,49
	103	92	109		12		5,19
	109,5	102	116,5		9		7,18
	124,5	115	133		7,5		8,00
2/0"	95	84	99,5	68	11	69	6,15
	103	92	109		12		6,85
	124,5	115	133		7,5		8,84
	142	135	155		8,5		9,66

Tab. 13-4 Dimensional table Type PKN with bar-agturn, size F to SW

17.4.3 Actuator assignment Type PKN with bar-agturn

Actuator assignment for bar-agturn type GD

Thread „Rp“	DN	4 bar actuators	6 bar actuators
1/2"	15	GD-052	GD-040
3/4"	20	GD-052	GD-052
1/0"	25	GD-063	GD-052
5/4"	32	GD-075	GD-063
3/2"	40	GD-083	GD-075
2/0"	50	GD-083	GD-075

Tab. 13-5 Actuator assignment for bar-agturn type GD

Actuator assignment for bar-agturn type GS

Thread „Rp“	DN	4 bar actuators	6 bar actuators
1/2"	15	GS-063-08	GS-063-08
3/4"	20	GS-075-08	GS-063-12
1/0"	25	GS-083-08	GS-075-12
5/4"	32	GS-092-08	GS-083-10
3/2"	40	GS-105-08	GS-092-12
2/0"	50	GS-125-08	GS-105-12

Tab. 13-6 Actuator assignment for bar-agturn type GS

The detailed dimensions of the rotary actuator can be found in the supplied manufacturer documentation.

17.5 Dimensional tables and dimensional drawings Type PKN with actubar

17.5.1 Dimensional drawing Type PKN with actubar

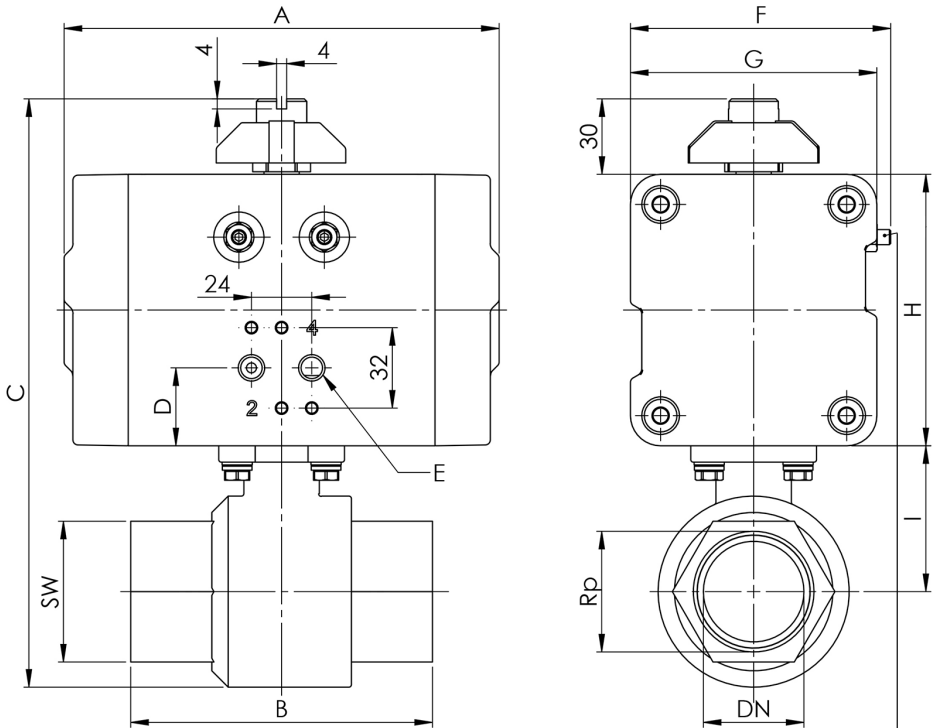

·Einstellschrauben bei AD/AS-004 und AD/AS-006 gegenüberliegend der Luftanschlüsse.

Adjusting screws at AD/AS-004 and AD/AS-006 opposite to the air connections.

Fig. 13-2 Dimensional drawing Type PKN with actubar type AD-008 (exemplary presentation)

17.5.2 Dimensional table Type PKN with actubar

Thread „Rp“	DN	Actuator size	A	B	C	D	E
1/2"	15	001	80	60	113	22,5	G 1/8"
		002	136		127	27,5	G 1/8"
		004	144		151	24	G 1/8"
3/4"	20	002	136	70	135	27,5	G 1/8"
		004	144		159	24	G 1/8"
		006	159		175	32	G 1/8"
1/0"	25	004	144	90	168	24	G 1/8"
		006	159		184	32	G 1/8"
		008	173		208	31	G 1/8"
5/4"	32	004	144	110	181	24	G 1/8"
		006	159		197	32	G 1/8"
		008	173		221	31	G 1/8"
		011	215		221	31	G 1/8"
3/2"	40	006	159	120	210	32	G 1/8"
		008	173		234	31	G 1/8"
		011	215		234	31	G 1/8"
		018	213		258	35	G 1/4"
2/0"	50	006	159	140	230	32	G 1/8"
		008	173		254	31	G 1/8"
		011	215		254	31	G 1/8"
		018	213		278	35	G 1/4"

Tab. 13-7 Dimensional table Type PKN with actubar, size A to E

Thread „Rp“	F	G	H	I	SW	Weight (kg)
1/2"	/	45	45	36	26	0,66
	/	59	59			1,05
	82	68	68			1,53
3/4"	/	59	59	39,5	32	1,19
	82	68	68			1,67
	90	76	84			2,27
1/0"	82	68	68	44	41	2,05
	90	76	84			2,65
	109	98	108			3,81
5/4"	82	68	68	51	50	2,53
	90	76	84			3,13
	109	98	108			4,29
	109	98	108			4,91
3/2"	90	76	84	58	56	3,75
	109	98	108			4,91
	109	98	108			5,53
	127	114	132			6,74
2/0"	90	76	84	68	69	5,41
	109	98	108			6,57
	109	98	108			7,19
	127	114	132			8,40

Tab. 13-8 Dimensional table Type PKN with actubar, size F to SW

17.5.3 Actuator assignment Type PKN with actubar

Actuator assignment for actubar type AD

Thread „Rp“	DN	4 bar actuators	6 bar actuators
1/2"	15	AD-002	AD-001
3/4"	20	AD-002	AD-002
1/0"	25	AD-004	AD-004
5/4"	32	AD-006	AD-004
3/2"	40	AD-008	AD-006
2/0"	50	AD-011	AD-006

Tab. 13-9 Actuator assignment for actubar type AD

Actuator assignment for actubar type AS

Thread „Rp“	DN	4 bar actuators	6 bar actuators
1/2"	15	AS-004-08	AS-004-08
3/4"	20	AS-006-06	AS-004-10
1/0"	25	AS-008-07	AS-006-10
5/4"	32	AS-011-08	AS-008-11
3/2"	40	AS-018-07	AS-011-10
2/0"	50	AS-018-08	AS-011-12

Tab. 13-10 Actuator assignment for actubar type AS

The detailed dimensions of the rotary actuator can be found in the supplied manufacturer documentation.

17.6 Dimensional tables and dimensional drawings Type EKN

17.6.1 Dimensional drawing Type EKN

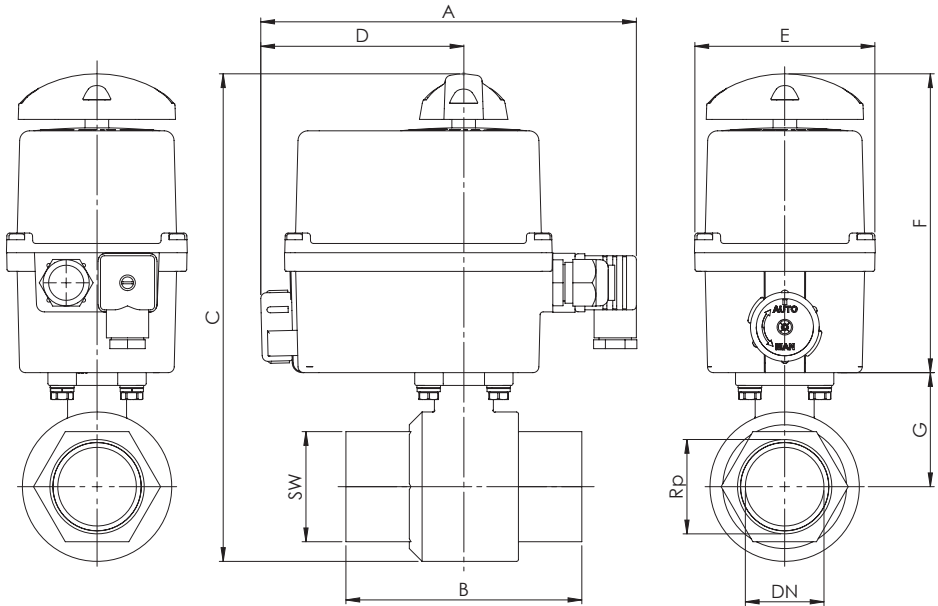

Fig. 14-3 Dimensional drawing Type EKI (exemplary representation with ER Plus rotary actuator)

17.6.2 Dimensional table Type EKN

Thread "RP"	DN	Actuator size	A	B	C	D	E
1/2"	15	ER20	191	60	205	103	92
3/4"	20	ER20	191	70	213	103	92
1/0"	25	ER20	191	90	222	103	92
5/4"	32	ER35	191	110	235	103	92
3/2"	40	ER60	205	120	272	106	128
2/0"	50	ER60	205	140	292	106	128

Tab. 14-11 Dimensional table Type EKN, size A to E

Thread "RP"	F	G	SW	Weight (kg)
1/2"	152	36	26	1,76
3/4"	152	39,5	32	1,90
1/0"	152	44	41	2,28
5/4"	152	51	50	2,76
3/2"	176	58	56	4,41
2/0"	176	68	69	6,07

Tab. 14-12 Dimensional table Type EKN, size F to SW

The detailed dimensions of the rotary actuator can be found in the supplied manufacturer documentation.

The bar products are comprehensively tested. The company bar therefore only guarantees the replacement or - at its sole discretion - the free repair of those components of the delivered products which, in the opinion of bar, have demonstrable manufacturing defects. Warranty claims due to defects or defects of title can be asserted within one (1) year from delivery/transfer of risk. Excluded from the warranty are damages due to normal product use or friction as well as damages due to changes or unauthorized repairs to the products for which bar rejects any claim for damages (direct or indirect). (Please refer to our website for detailed information.) All deliveries are subject to the General Conditions of Sale which can be found at www.bar-gmbh.de.

The descriptions and images contained in this product data sheet are for informational purposes only and are not guaranteed. bar GmbH reserves the right to make technical and constructive changes to its products without prior notice.

Warranty: All purchases and sales contracts expressly require the Purchaser to accept the General Terms and Conditions of Sale and Delivery which can be found on www.bar-gmbh.de/agb. bar GmbH hereby objects to any deviating or additional condition to the General Terms and Conditions of Sale and Delivery which has been communicated to the Purchaser in any form without the written consent of a representative of bar GmbH.

bar
A **WATTS** Brand

bar pneumatische Steuerungssysteme GmbH
Auf der Hohl 1 • 53547 Dattenberg • Deutschland
Tel. +49 (0)2644 96070 • Fax +49 (0)2644 960735
bar-info@wattswater.com • www.bar-gmbh.de