

# actubar<sup>®</sup> with DNV-Certificate

The intelligent actuator  
for marine equipment and systems

## Technical data sheet



Type AD-DV-001 + AD/AS-DV-002

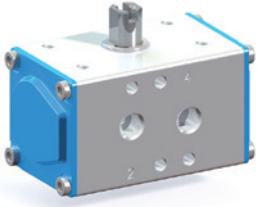

Type AD/AS-DV-004 bis -230



Type AD/AS-DV-360 bis -1200

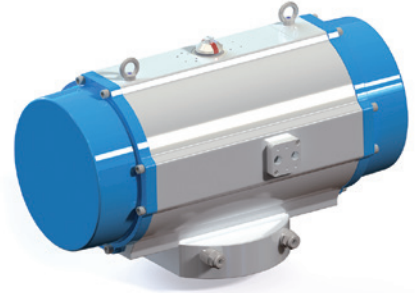

## Objective AD/AS-DV

The actubar is the intelligently equipped generation of our pneumatic part-turn actuators. Externally unmistakable and technically unique, the actubar offers completely new advantages that can be used for flexible adaptations to specific plant which results in higher production efficiency.

The actubar is the main component of the bar-vacotrol® valve control system, a modular, intelligent system for monitoring and controlling automatic valves.

Actuator and control units form a system family for control tasks, which makes efficient use of the installation space with a clear design and no piping. The result is optimized compressed air consumption, sustainable processes, and higher cost efficiency for smooth plant operation.

## Additional benefit by bar-vacotrol® AD/AS-DV

In combination with our directly mountable system components bar-positrol, bar-posturn2 or bar-positswitch, actubar can also be used to control shut-off valves cost-effectively.

The openings of the pneumatic air duct as a direct connection between the actuator and the control unit are equipped with a are closed with a blow-out-proof and reusable screw. When retrofitting control units from the bar-vacotrol® series, simply unscrew the screw plug from the actuator housing to open the direct connection.

bar-vacotrol® as an integrated air duct realizes an increased level in the reduction of interfaces between the actuator and the control unit. The suitably developed generation of control components eliminates the need for external piping and is easily accessible and logical to operate. The integrated air duct is predestined for an optimal realization of the interface according to VDI/VDE 3847-2.

Emissions due to leakages are reduced by eliminating susceptible pneumatic screw fittings and the small number of robust sealing points. A dead volume in lines is eliminated. The process operation is less susceptible to faults and more insensitive to vibrations.

External influences lead to damage and failures much less frequently. For the plants, this results in longer running times and higher availability.

When changing components, the modular system eliminates the need to adapt pipelines. The changeover process of components can be integrated into the processes without any problems, and assembly times are reduced considerably.



bar-vacotrol® interface closed

## Benefits for plant safety AD/AS-DV

- the unique construction of the actubar enables the addition of components acc. to VDI/VDE 3847 without hose connections or conduit
- positioner and limit switch boxes with solenoid valves can be mounted directly, without conduit installation and constitute a compact unit in combination with actubar-actuators
- end position can be adjusted at 0° and 90° from +5° to -10°
- from size actubar AD/AS-360, the pneumatic air supply can be changed very easily from 1/4" to 1/2" air connection in the standard version using an adapter plate
- simple insertion and removal of safety springs
- optional coatings and materials enable usage even in aggressive environments
- blowout-secure pinion minimizes the danger of accidents
- elevated failsafe performance by our SIL 3 certified actuators
- The DV certification awarded by TÜV Rheinland confirms the robustness and suitability of the actuator for applications in the maritime, off-shore and other demanding operating conditions.

## Benefits for better cost efficiency AD/AS-DV

- From actubar AD/AS-360 onwards, the pneumatic air supply can be easily changed from a 1/4" to a 1/2" air connection via an adapter plate.
- the standard interface (VDI / VDE 3845) allows mounting of all commercially available signal units
- reduced warehousing by using equal end-caps for single as well as double-acting actuators
- flexible automation of valves through various ISO flange interfaces per actuator size for many versions of the series
- long service life via plain-bearing system which reaches all moving parts
- octagonal pinion-connection enables actubar to fit universally onto valves with parallel or diagonally operating shafts

## DNV certified for these applications AD/AS-DV

### For offshore and shipbuilding, vessels like:

- Special vessels
- Container ships
- Tankers
- Passenger ships and ferries
- Surface warships and submarines

### Applications in specific systems:

- Lubricating grease processing
- Fuel processing
- Cooling systems on ships
- Energy recuperation
- Bilge systems
- Fire fighting systems
- Ballast Water Distribution
- Drinking Water Treatment
- Hot Water Treatment
- Wastewater Treatment



## Technical data AD/AS-DV

	Standard model	Options available
Description	pneumatic double piston actuator type AD = double-acting type AS = single-acting (with spring return)	
Constructional features	rack and pinion principle with self-centering piston guides in the casing; single-acting: with bar safety springs	
Mounting position	any orientation	
Standards	interface actuator signal unit: acc. to VDI/VDE 3845 (NAMUR) and VDI/VDE 3847 interface actuator/control valve: acc. to NAMUR i.e. VDI/VDE 3845 interface actuator/valve: 4, i.e. 8 internal threaded in actuator casing acc. to EN ISO 5211	differing mounting and connecting dimensions possible  pinion optional with internal double-D or acc. to DIN ISO 5211
Materials	casing: aluminium alloy, anodized caps: aluminium alloy pistons/racks: aluminium alloy pinion: corrosion-protected steel seals: NBR bearings: self-lubricating plastic screws: stainless steel A2	Casing: anodized, powder-coated, PTFE Caps: PTFE  Pinion: stainless steel AISI 303; AISI 316 Seals: FKM
Ambient temperature	up to AD/AS-230: -40°C to +80°C AD/AS-360 to -1200: -20°C to +80°C	AD/AS-360 to -1200 Low temperature version: -40°C to +80°C AD/AS-001 to -1200 High temperature version: -20°C to +160°C
Rated pivoting angle	double and single-acting: 90° rated pivoting angle as standard from +5° to -10° adjustable in both end positions	
Torque	2.5 Nm to 8,490 Nm	
Control pressure	2 to 8 bar	
Control medium / Quality	filtered air in respect of remaining oil content, dust and water minimum according to DIN ISO 8573-1:2010 [7: - :4]	also upon request: other non-aggressive gaseous or liquid mediums
Certificates	SIL 3 by TÜV Rheinland, test basis IEC61508 Parts 1-2 and 4-7:2010  Certificate No: TAA00002M9 DNV rules for classification – Ships Pt.4 Ch.6 Piping systems	

## Function – double-acting AD/AS-DV

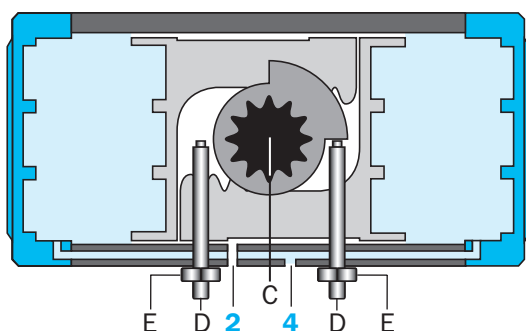

When pressure is applied to both of the external chambers through input connection „4“, then the pistons move together into the basic position (0°). The force from both pistons is transferred onto the pinion „C“ via the toothed rack. If input connection „2“ is given pressure and „4“ as exhaust, then the pistons move apart into the 90° position.

In both positions, the pivoting angle can be set via the adjusting screws „D“ to a position of + 5° and - 10° in a depressurised condition. When the correct angle is reached, then fix with locking nut „E“.

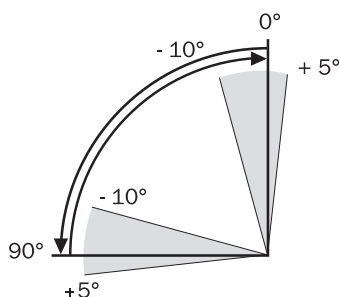
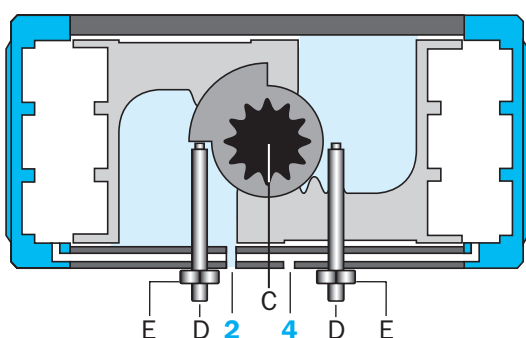

## Torque for double-acting actuators, type AD-DV [Nm]

Type	Control pressure P <sub>st</sub> [bar]										
	2	2,5	3	3,5	4	4,5	5	5,5	6	7	8
AD - 001	2,5	3,2	3,8	4,4	5,1	5,7	6,4	7,0	7,6	8,9	10,2
AD - 002	4	5,2	6,4	7,5	8,6	9,7	10,8	11,9	13	15,5	18
AD - 004	8	10	12	14	16	18	20	22	24	28	32
AD - 006	13	16	19	22	25	28	32	35	38	44	51
AD - 008	16	20	24	28	32	36	40	44	48	56	64
AD - 011	23	29	35	40	46	52	58	63	69	81	92
AD - 018	36	45	54	63	72	81	90	99	108	126	144
AD - 026	52	65	78	91	104	117	130	143	156	182	208
AD - 037	74	93	111	129	148	166	185	204	222	259	296
AD - 050	100	125	150	175	200	225	250	275	300	350	400
AD - 076	152	190	228	266	304	342	380	418	456	532	608
AD - 110	220	275	330	385	440	495	550	605	660	770	880
AD - 160	323	403	484	565	645	726	807	887	968	1129	1290
AD - 230	463	579	695	811	927	1043	1159	1274	1390	1622	1854
AD - 360	746	933	1119	1306	1492	1679	1865	2052	2238	2611	2984
AD - 520	1040	1300	1560	1820	2080	2340	2600	2860	3120	3640	4160
AD - 800	1560	1950	2340	2730	3120	3510	3900	4290	4680	5460	6240
AD - 1200	2426	3032	3639	4245	4851	5458	6064	6671	7277	8490	

## Function – single-acting AD/AS-DV

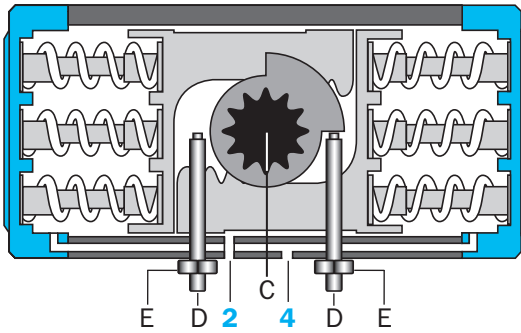

In the single-acting model the springs push the pistons back into the basic position and air is exhausted from connection „2“.

The number of springs can be selected to correspond to the applied pressure.

Adjustment of the end positions is described in „Function double-acting“.

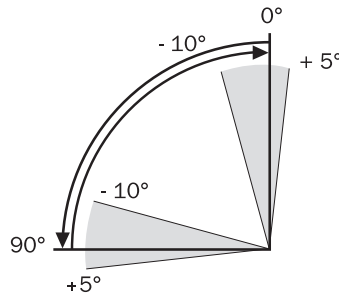
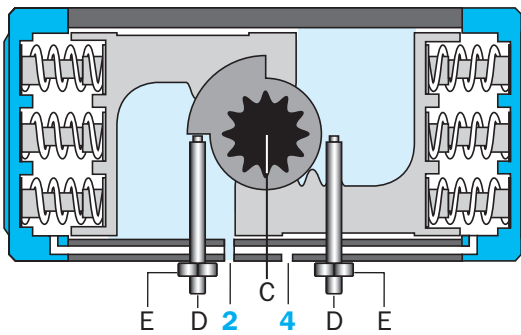

## Torques – single-acting actuators, type AS-DV [Nm]

		Spring force		Pneumatic applied torque Md N [Nm] at min. control pressure PSt [bar]																							
		Md F [Nm]		2,0		2,5		3,0		3,5		4,0		4,5		5,0		5,5		6,0		7,0		8,0			
Type	No. springs	Md min	Md max	min	max	min	max	min	max	min	max	min	max	min	max	min	max	min	max	min	max	min	max	min	max		
AS-002	2	1,0	1,6	2,4	3,1	3,6	4,3	4,8	5,5	6,0	6,7	7,1	7,8	8,2	8,9	9,4	10,0	10,5	11,1	11,6	12,2	13,9	14,5	16,2	16,8		
	4	2,1	3,3	0,8	2,1	2,0	3,3	3,1	4,5	4,3	5,7	5,4	6,8	6,5	7,9	7,5	9,0	8,7	10,1	9,8	11,2	12,2	13,6	14,7	16,0		
	6	3,2	5,1					1,0	3,2	2,3	4,5	3,5	5,7	4,7	6,9	5,8	8,0	7,0	9,2	8,2	10,4	10,6	12,8	12,9	15,1		
	8	4,4	6,9									1,7	4,6	3,0	5,8	4,2	7,0	5,4	8,1	6,5	9,2	8,9	11,5	11,4	13,9		
	10	5,4	8,6											1,2	4,8	2,4	6,0	3,6	7,1	4,7	8,2	7,0	10,5	9,4	12,7		
AS-004	2	1	3	5	7	7	9	9	11	11	12	13	14	15	16	17	18	19	20	21	22	25	26	29	30		
	4	3	5	3	5	5	7	7	9	9	11	10	13	12	15	14	17	16	19	18	21	22	25	26	29		
	6	4	8			2	6	4	8	6	10	8	12	10	14	12	16	14	18	16	20	20	24	24	28		
	8	5	11					1	7	3	9	5	10	7	12	9	14	11	16	13	18	17	22	21	26		
	10	7	13							1	7	3	9	4	11	6	13	8	15	10	17	14	21	18	25		
AS-006	2	2	4	8	11	12	14	15	17	18	20	21	23	24	26	27	30	31	33	34	36	40	42	46	48		
	4	4	8	4	8	7	12	11	15	14	18	17	21	20	24	23	27	26	31	30	34	36	40	42	46		
	6	6	13			3	10	6	13	10	16	13	19	16	22	19	25	22	28	25	32	32	38	38	44		
	8	8	17					2	11	5	14	8	17	12	20	15	23	18	26	21	30	27	36	34	42		
	10	11	21							1	12	4	15	7	18	11	21	14	24	17	27	23	34	30	40		
	12	13	25										3	16	6	19	10	22	13	25	19	32	25	38			



## Torques – single-acting actuators, type AS-DV [Nm]

Spring force			Pneumatic applied torque Md N [Nm] at min. control pressure PSt [bar]																							
Type	No. springs	Md F [Nm]		2,0		2,5		3,0		3,5		4,0		4,5		5,0		5,5		6,0		7,0		8,0		
		min	max	min	max	min	max	min	max	min	max	min	max	min	max	min	max	min	max	min	max	min	max	min	max	
AS-008	3	5	8	8	12	12	16	16	20	20	24	24	28	28	32	36	36	40	40	44	48	52	56	60		
	4	6	11	5	10	9	14	13	18	17	22	21	26	25	30	29	34	33	38	37	42	45	50	53	58	
	5	8	14	2	9	6	13	10	17	14	21	18	25	22	29	26	33	30	37	34	41	42	49	50	57	
	6	9	17			3	11	7	15	11	19	15	23	19	27	23	31	27	35	31	39	39	47	47	55	
	7	11	20					4	14	8	18	12	22	16	26	20	30	24	34	28	38	36	46	44	54	
	8	12	22					2	12	6	16	10	20	14	24	18	28	22	32	26	36	34	44	42	52	
	9	14	25							3	15	7	19	11	23	15	27	19	31	23	35	31	43	39	51	
	10	15	28									4	17	8	21	12	25	16	29	20	33	28	41	36	49	
	11	17	31									1	16	5	20	9	24	13	28	17	32	25	40	33	48	
	12	18	34											2	18	6	22	10	26	14	30	22	38	30	46	
	13	20	36													4	21	8	25	12	29	20	37	28	45	
	14	21	39													1	19	5	23	9	27	17	35	25	43	
	AS-011	3	6	12	11	17	17	23	23	29	28	34	34	40	40	46	46	52	51	57	57	63	69	75	80	86
		4	8	16	7	15	13	21	19	27	24	32	30	38	36	44	42	50	47	55	53	61	65	73	76	84
5		10	20	3	13	9	19	15	25	20	30	26	36	32	42	38	48	43	53	49	59	61	71	72	82	
6		12	24			5	17	11	23	16	28	22	34	28	40	34	46	39	51	45	57	57	69	68	80	
7		14	28			1	15	7	21	12	26	18	32	24	38	30	44	35	49	41	55	53	67	64	78	
8		16	31					4	19	9	24	15	30	21	36	27	42	32	47	38	53	50	65	61	76	
9		18	35							5	22	11	28	17	34	23	40	28	45	34	51	46	63	57	74	
10		20	39							1	20	7	26	13	32	19	38	24	43	30	49	42	61	53	72	
11		22	43								3	24	9	30	15	36	20	41	26	47	38	59	49	70		
12		24	47											5	28	11	34	16	39	22	45	34	57	45	68	
13		26	51											1	26	7	32	12	37	18	43	30	55	41	66	
14		28	55													3	30	8	35	14	41	26	53	37	64	
AS-018		3	9	18	18	27	27	36	36	45	45	54	54	63	63	72	72	81	81	90	90	99	108	117	126	135
		4	12	24	12	24	21	33	30	42	39	51	48	60	57	69	66	78	75	87	84	96	102	114	120	132
	5	15	30	6	21	15	30	24	39	33	48	42	57	51	66	60	75	69	84	78	93	96	111	114	129	
	6	18	36			9	27	18	36	27	45	36	54	45	63	54	72	63	81	72	90	90	108	108	126	
	7	21	42			3	24	12	33	21	42	30	51	39	60	48	69	57	78	66	87	84	105	102	123	
	8	24	48					6	30	15	39	24	48	33	57	42	66	51	75	60	84	78	102	96	120	
	9	27	54							9	36	18	45	27	54	36	63	45	72	54	81	72	99	90	117	
	10	30	60							3	33	12	42	21	51	30	60	39	69	48	78	66	96	84	114	
	11	33	66									6	39	15	48	24	57	33	66	42	75	60	93	78	111	
	12	36	72											9	45	18	54	27	63	36	72	54	90	72	108	
	13	39	78											3	42	12	51	21	60	30	69	48	87	66	105	
	14	42	84													6	48	15	57	24	66	42	84	60	102	
	AS-026	3	13	27	25	39	38	52	51	65	64	78	77	91	90	104	103	117	116	130	129	143	155	169	181	195
		4	17	35	17	35	30	48	43	61	56	74	69	87	82	100	95	113	108	126	121	139	147	165	173	191
5		21	44	8	31	21	44	34	57	47	70	60	83	73	96	86	109	99	122	112	135	138	161	164	187	
6		26	53			12	40	25	53	38	66	51	79	64	92	77	105	90	118	103	131	129	157	155	183	
7		30	62			3	35	16	48	29	61	42	74	55	87	68	100	81	113	94	126	120	152	146	178	
8		34	71					7	44	20	57	33	70	46	83	59	96	72	109	85	122	111	148	137	174	
9		38	80							11	53	24	66	37	79	50	92	63	105	76	118	102	144	128	170	
10		43	89							2	49	15	62	28	75	41	88	54	101	67	114	93	140	119	166	
11		47	98								6	57	19	70	32	83	45	96	58	109	84	135	110	161		
12		51	106											11	66	24	79	37	92	50	105	76	131	102	157	
13		55	115											2	62	15	75	28	88	41	101	67	127	93	153	
14		60	124													6	71	19	84	32	97	58	123	84	149	
AS-037		3	21	40	34	53	53	72	71	90	89	108	108	127	126	145	145	164	163	182	182	201	219	238	256	275
		4	27	53	21	47	40	66	58	84	76	102	95	121	113	139	132	158	150	176	169	195	206	232	243	269
	5	34	66	8	40	27	59	45	77	63	95	82	114	100	132	119	151	137	169	156	188	193	225	230	262	
	6	41	80			13	52	31	70	49	88	68	107	86	125	105	144	123	162	142	181	179	218	216	255	
	7	48	93					18	63	36	81	55	100	73	118	92	137	110	155	129	174	166	211	203	248	
	8	55	106					5	56	23	74	42	93	60	111	79	130	97	148	116	167	153	204	190	241	
	9	62	119							10	67	29	86	47	104	66	123	84	141	103	160	140	197	177	234	
	10	69	133								15	79	33	97	52	116	70	134	89	153	126	190	163	227		
	11	75	146								2	73	20	91	39	110	57	128	76	147	113	184	150	221		
	12	82	159											7	84	26	103	44	121	63	140	100	177	137	214	
	13	89	173													12	96	30	114	49	133	86	170	123	207	
	14	96	186															17	107	36	126	73	163	110	200	

## Torques – single-acting actuators, type AS-DV [Nm]

		Spring force		Pneumatic applied torque Md N [Nm] at min. control pressure PSt [bar]																						
		Md F [Nm]		2,0		2,5		3,0		3,5		4,0		4,5		5,0		5,5		6,0		7,0		8,0		
Type	No. springs	Md min	Md max	min	max	min	max	min	max	min	max	min	max	min	max	min	max	min	max	min	max	min	max	min	max	
AS-050	3	28	53	47	72	72	97	97	122	122	147	147	172	172	197	197	222	222	247	247	272	272	297	322	347	372
	4	37	71	29	63	54	88	79	113	104	138	129	163	154	188	179	213	204	238	229	263	279	313	329	363	
	5	46	88	12	54	37	79	62	104	87	129	112	154	137	179	162	204	187	229	212	254	262	304	312	354	
	6	56	106			19	69	44	94	69	119	94	144	119	169	144	194	169	219	194	244	244	294	294	344	
	7	65	124					26	85	51	110	76	135	101	160	126	185	151	210	176	235	226	285	276	335	
	8	74	142					8	76	33	101	58	126	83	151	108	176	133	201	158	226	208	276	258	326	
	9	83	159							16	92	41	117	66	142	91	167	116	192	141	217	191	267	241	317	
	10	93	177									23	107	48	132	73	157	98	182	123	207	173	257	223	307	
	11	102	195									5	98	30	123	55	148	80	173	105	198	155	248	205	298	
	12	111	212											13	114	38	139	63	164	88	189	138	239	188	289	
	13	121	230													20	129	45	154	70	179	120	229	170	279	
	14	130	248															27	145	52	170	102	220	152	270	
	AS-076	3	42	80	72	110	110	148	148	186	186	224	224	262	262	300	300	338	338	376	376	414	452	490	528	566
		4	56	107	45	96	83	134	121	172	159	210	197	248	235	286	273	324	311	362	349	400	425	476	501	552
5		70	134	18	82	56	120	94	158	132	196	170	234	208	272	246	310	284	348	322	386	398	462	474	538	
6		84	161			29	106	67	144	105	182	143	220	181	258	219	296	257	334	295	372	371	448	447	524	
7		98	188			2	92	40	130	78	168	116	206	154	244	192	282	230	320	268	358	344	434	420	510	
8		112	214					14	116	52	154	90	192	128	230	166	268	204	306	242	344	318	420	394	496	
9		126	241							25	140	63	178	101	216	139	254	177	292	215	330	291	406	367	482	
10		140	268									36	164	74	202	112	240	150	278	188	316	264	392	340	468	
11		154	295									9	150	47	188	85	226	123	264	161	302	237	378	313	454	
12		168	321											21	174	59	212	97	250	135	288	211	364	287	440	
13		183	348													32	197	70	235	108	273	184	349	260	425	
14		197	375													5	183	43	221	81	259	157	335	233	411	
AS-110		3	66	116	104	154	159	209	214	264	269	319	324	374	379	429	434	484	489	539	544	594	654	704	764	814
		4	88	155	65	132	120	187	175	242	230	297	285	352	340	407	395	462	450	517	505	572	615	682	725	792
	5	110	193	27	110	82	165	137	220	192	275	247	330	302	385	357	440	412	495	467	550	577	660	687	770	
	6	132	232			43	143	98	198	153	253	208	308	263	363	318	418	373	473	428	528	538	638	648	748	
	7	154	271			4	121	59	176	114	231	169	286	224	341	279	396	334	451	389	506	499	616	609	726	
	8	176	309					21	154	76	209	131	264	186	319	241	374	296	429	351	484	461	594	571	704	
	9	197	348							37	188	92	243	147	298	202	353	257	408	312	463	422	573	532	683	
	10	219	387									53	221	108	276	163	331	218	386	273	441	383	551	493	661	
	11	241	425									15	199	70	254	125	309	180	364	235	419	345	529	455	639	
	12	263	464											31	232	86	287	141	342	196	397	306	507	416	617	
	13	285	503													47	265	102	320	157	375	267	485	377	595	
	14	307	541													9	243	64	298	119	353	229	463	339	573	
	AS-160	3	84	160	162	239	243	319	323	400	404	481	485	561	565	642	646	723	727	803	807	884	969	1045	1130	1207
		4	112	214	109	211	189	292	270	372	351	453	431	534	512	614	593	695	673	775	754	856	915	1017	1076	1179
5		140	267	55	183	136	264	216	344	297	425	378	506	458	586	539	667	620	748	700	828	862	989	1023	1151	
6		168	321			82	236	163	316	244	397	324	478	405	558	486	639	566	720	647	800	808	962	969	1123	
7		195	374					109	288	190	369	271	450	351	530	432	611	513	692	593	772	755	934	916	1095	
8		223	428					56	261	137	341	217	422	298	502	379	583	459	664	540	744	701	906	862	1067	
9		251	481							83	313	164	394	244	475	325	555	406	636	486	717	648	878	809	1039	
10		279	535									110	366	191	447	272	527	352	608	433	689	594	850	756	1011	
11		307	588											137	419	218	499	299	580	379	661	541	822	702	983	
12		335	642													165	471	245	552	326	633	487	794	649	955	
13		363	695															192	524	272	605	434	766	595	927	
14		391	749																	219	577	380	738	542	900	
AS-230		3	128	221	242	335	358	451	474	567	590	683	706	799	822	915	938	1030	1053	1146	1169	1262	1401	1494	1633	1725
		4	171	295	169	293	285	408	400	524	516	640	632	756	748	872	864	988	980	1103	1096	1219	1327	1451	1559	1683
	5	214	368	95	250	211	366	327	482	443	597	559	713	674	829	790	945	906	1061	1022	1177	1254	1408	1485	1640	
	6	256	442	21	207	137	323	253	439	369	555	485	671	601	786	717	902	832	1018	948	1134	1180	1366	1412	1597	
	7	299	516			64	280	180	396	295	512	411	628	527	744	643	860	759	975	875	1091	1106	1323	1338	1555	
	8	342	589					106	353	222	469	338	585	453	701	569	817	685	933	801	1048	1033	1280	1264	1512	
	9	384	663					32	311	148	427	264	542	380	658	496	774	611	890	727	1006	959	1237	1191	1469	
	10	427	737							74	384	190	500	306	616	422	731	538	847	654	963	885	1195	1117	1426	
	11	470	810									117	457	232	573	348	689	464	804	580	920	812	1152	1043	1384	
	12	513	884											159	530	275	646	390	762	506	878	738	1109	970	1341	
	13	555	958													201	603	317	719	433	835	664	1067	896	1298	
	14	598	1031															243	676	359	792	591	1024	822	1256	



## Torques – single-acting actuators, type AS-DV [Nm]

Spring force				Pneumatic applied torque Md N [Nm] at min. control pressure Pst [bar]																							
Type	No. springs	Md F [Nm]		2,0		2,5		3,0		3,5		4,0		4,5		5,0		5,5		6,0		7,0		8,0			
		Md min	Md max	min	max	min	max	min	max	min	max	min	max	min	max	min	max	min	max	min	max	min	max	min	max		
AS-360	1	74	112,5	633,5	672	820	858,5	1006,5	1045	1193	1231,5	1379,5	1418	1566	1604,5	1752,5	1791	1939	1977,5	2125,5	2164	2498,5	2537	2871,5	2910		
	2	148	225	521	598	707,5	784,5	894	971	1080,5	1157,5	1267	1344	1453,5	1530,5	1640	1717	1826,5	1903,5	2013	2090	2386	2463	2759	2836		
	3	222	337,5	408,5	524	595	710,5	781,5	897	968	1083,5	1154,5	1270	1341	1456,5	1527,5	1643	1714	1829,5	1900,5	2016	2273,5	2389	2646,5	2762		
	4	296	450	296	450	482,5	636,5	669	823	855,5	1009,5	1042	1196	1228,5	1382,5	1415	1569	1601,5	1755,5	1788	1942	2161	2315	2534	2688		
	5	370	562,5	183,5	376	370	562,5	556,5	749	743	935,5	929,5	1122	1116	1308,5	1302,5	1495	1489	1681,5	1675,5	1868	2048,5	2241	2421,5	2614		
	6	444	675	71	302	257,5	488,5	444	675	630,5	861,5	817	1048	1003,5	1234,5	1190	1421	1376,5	1607,5	1563	1794	1936	2167	2309	2540		
	7	518	787,5			145	414,5	331,5	601	518	787,5	704,5	974	891	1160,5	1077,5	1347	1264	1533,5	1450,5	1720	1823,5	2093	2196,5	2466		
	8	592	900			32,5	340,5	219	527	405,5	713,5	592	900	778,5	1086,5	965	1273	1151,5	1459,5	1338	1646	1711	2019	2084	2392		
	9	666	1012,5						106,5	453	293	639,5	479,5	826	666	1012,5	852,5	1199	1039	1385,5	1225,5	1572	1598,5	1945	1971,5	2318	
	10	740	1125								180,5	565,5	367	752	553,5	938,5	740	1125	926,5	1311,5	1113	1498	1486	1871	1859	2244	
	11	814	1237,5								68	491,5	254,5	678	441	864,5	627,5	1051	814	1237,5	1000,5	1424	1373,5	1797	1746,5	2170	
	12	888	1350											142	604	328,5	790,5	515	977	701,5	1163,5	888	1350	1261	1723	1634	2096
AS-520	1	98	162	878	942	1138	1202	1398	1462	1658	1722	1918	1982	2178	2242	2438	2502	2698	2762	2958	3022	3478	3542	3998	4062		
	2	196	324	716	844	976	1104	1236	1364	1496	1624	1756	1884	2016	2144	2276	2404	2536	2664	2796	2924	3316	3444	3836	3964		
	3	294	486	554	746	814	1006	1074	1266	1334	1526	1594	1786	1854	2046	2114	2306	2374	2566	2634	2826	3154	3346	3674	3866		
	4	392	648	392	648	652	908	912	1168	1172	1428	1432	1688	1692	1948	1952	2208	2212	2468	2472	2728	2992	3248	3512	3768		
	5	490	810	230	550	490	810	750	1070	1010	1330	1270	1590	1530	1850	1790	2110	2050	2370	2310	2630	2830	3150	3350	3670		
	6	588	972	68	452	328	712	588	972	848	1232	1108	1492	1368	1752	1628	2012	1888	2272	2148	2532	2668	3052	3188	3572		
	7	686	1134			166	614	426	874	686	1134	946	1394	1206	1654	1466	1914	1726	2174	1986	2434	2506	2954	3026	3474		
	8	784	1296			4	516	264	776	524	1036	784	1296	1044	1556	1304	1816	1564	2076	1824	2336	2344	2856	2864	3376		
	9	882	1458					102	678	362	938	622	1198	882	1458	1142	1718	1402	1978	1662	2238	2182	2758	2702	3278		
	10	980	1620							200	840	460	1100	720	1360	980	1620	1240	1880	1500	2140	2020	2660	2540	3180		
	11	1078	1782							38	742	298	1002	558	1262	818	1522	1078	1782	1338	2042	1858	2562	2378	3082		
	12	1176	1944											136	904	396	1164	656	1424	916	1684	1176	1944	1696	2464	2216	2984
AS-800	1	108	185	1375	1452	1765	1842	2155	2232	2545	2622	2935	3012	3325	3402	3715	3792	4105	4182	4495	4572	5275	5352	6055	6132		
	2	216	370	1190	1344	1580	1734	1970	2124	2360	2514	2750	2904	3140	3294	3530	3684	3920	4074	4310	4464	5090	5244	5870	6024		
	3	324	555	1005	1236	1395	1626	1785	2016	2175	2406	2565	2796	2955	3186	3345	3576	3735	3966	4125	4356	4905	5136	5685	5916		
	4	432	740	820	1128	1210	1518	1600	1908	1990	2298	2380	2688	2770	3078	3160	3468	3550	3858	3940	4248	4720	5028	5500	5808		
	5	540	925	635	1020	1025	1410	1415	1800	1805	2190	2195	2580	2585	2970	2975	3360	3365	3750	3755	4140	4535	4920	5315	5700		
	6	648	1110	450	912	840	1302	1230	1692	1620	2082	2010	2472	2400	2862	2790	3252	3180	3642	3570	4032	4350	4812	5130	5592		
	7	756	1295	265	804	655	1194	1045	1584	1435	1974	1825	2364	2215	2754	2605	3144	2995	3534	3385	3924	4165	4704	4945	5484		
	8	864	1480	80	696	470	1086	860	1476	1250	1866	1640	2256	2030	2646	2420	3036	2810	3426	3200	3816	3980	4596	4760	5376		
	9	972	1665			285	978	675	1368	1065	1758	1455	2148	1845	2538	2235	2928	2625	3318	3015	3708	3795	4488	4575	5268		
	10	1080	1850			100	870	490	1260	880	1650	1270	2040	1660	2430	2050	2820	2440	3210	2830	3600	3610	4380	4390	5160		
	11	1188	2035					305	1152	695	1542	1085	1932	1475	2322	1865	2712	2255	3102	2645	3492	3425	4272	4205	5052		
	12	1296	2220					120	1044	510	1434	900	1824	1290	2214	1680	2604	2070	2994	2460	3384	3240	4164	4020	4944		
	13	1404	2405							325	1326	715	1716	1105	2106	1495	2496	1885	2886	2275	3276	3055	4056	3835	4836		
	14	1512	2590							140	1218	530	1608	920	1998	1310	2388	1700	2778	2090	3168	2870	3948	3650	4728		
	15	1620	2775									345	1500	735	1890	1125	2280	1515	2670	1905	3060	2685	3840	3465	4620		
	16	1728	2960									160	1392	550	1782	940	2172	1330	2562	1720	2952	2500	3732	3280	4512		
AS-1200	1	244	363	2063	2183	2670	2790	3276	3396	3883	4002	4489	4609	5096	5215	5702	5822	6308	6428	6915	7034	8128	8247				
	2	487	726	1701	1940	2307	2546	2914	3153	3520	3759	4126	4366	4733	4972	5339	5578	5946	6185	6552	6791	7765	8004				
	3	730	1088	1338	1697	1945	2303	2551	2910	3157	3516	3764	4123	4370	4729	4977	5335	5583	5942	6189	6548	7402	7761				
	4	973	1406	975	1454	1582	2060	2188	2667	2795	3273	3401	3880	4008	4486	4614	5092	5220	5699	5827	6305	7040	7518				
	5	1216	1814	613	1211	1219	1817	1826	2424	2432	3030	3038	3637	3645	4243	4251	4849	4858	5456	5464	6062	6677	7275				
	6	1459	2176	250	968	857	1574	1463	2180	2069	2787	2676	3393	3282	4000	3889	4606	4495	5213	5101	5819	6314	7032				
	7	1702	2539			494	1331	1100	1937	1706	2544	2313	3150	2920	3757	3526	4363	4132	4969	4739	5576	5952	6789				
	8	1945	2902			131	1088	738	1694	1344	2301	1950	2907	2557	3514	3163	4120	3770	4726	4376	5333	5589	6546				
	9	2188	3264					375	1451	981	2058	1588	2664	2194	3270	2801	3877	3407	4483	4013	5090	5226	6303				
	10	2431	3627							619	1815	1225	2421	1832	3027	2438	3634	3044	4240	3651	4847	4864	6059				
	11	2674	3990							256	1571	862	2178	1469	2784	2075	3391	2682	3997	3288	4604	4501	5816				
	12	2918	4352									500	1935	1106	2541	1713	3148	2319	3754	2925	4360	4138	5573				

## Drawings for actubar type AD-DV-001 and type AD/AS-DV-002

**Type AD/AS-002**

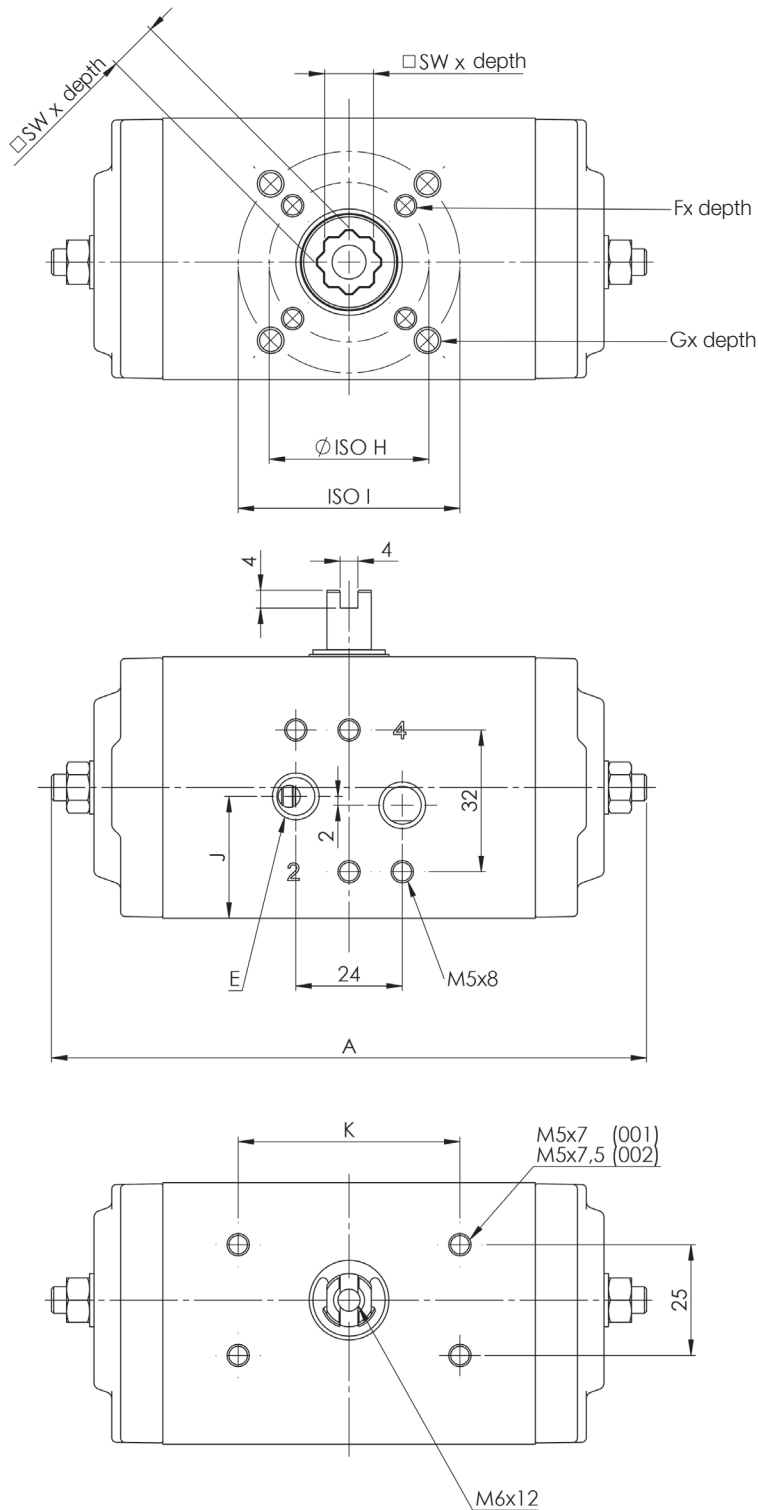

**Type AD-001**

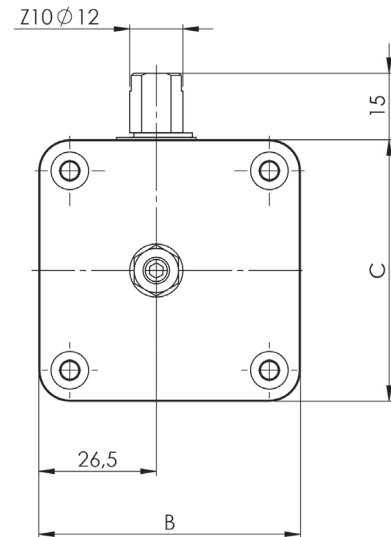
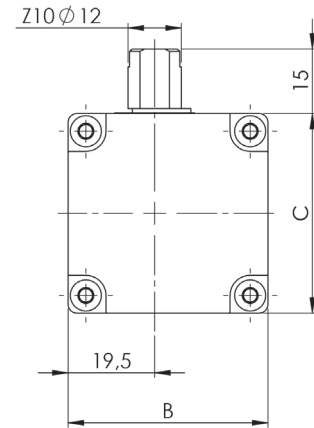

## Drawings for actubar type AD/AS-DV-004 to -006

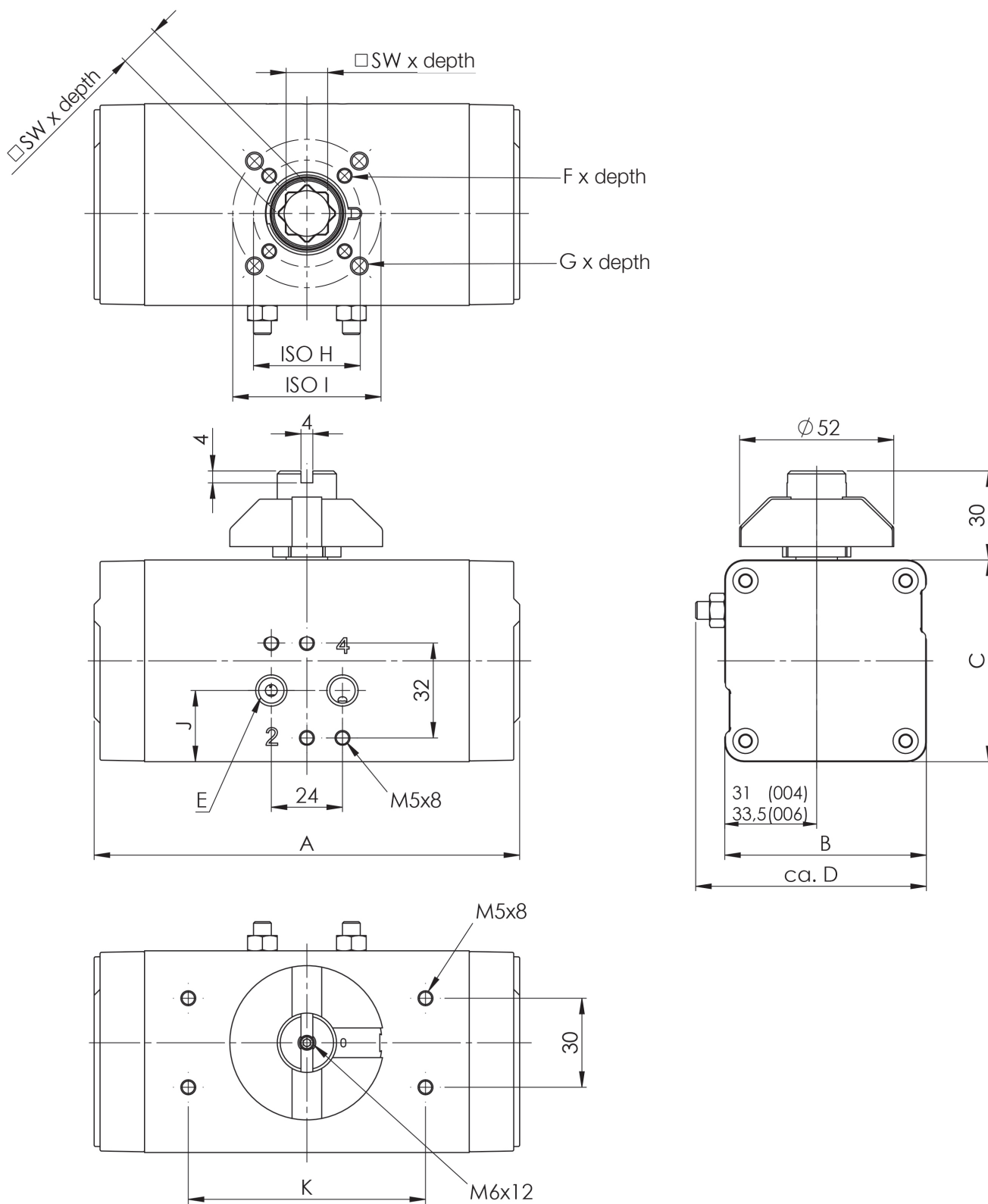

## Drawings for actubar types AD/AS-DV-008 to -230

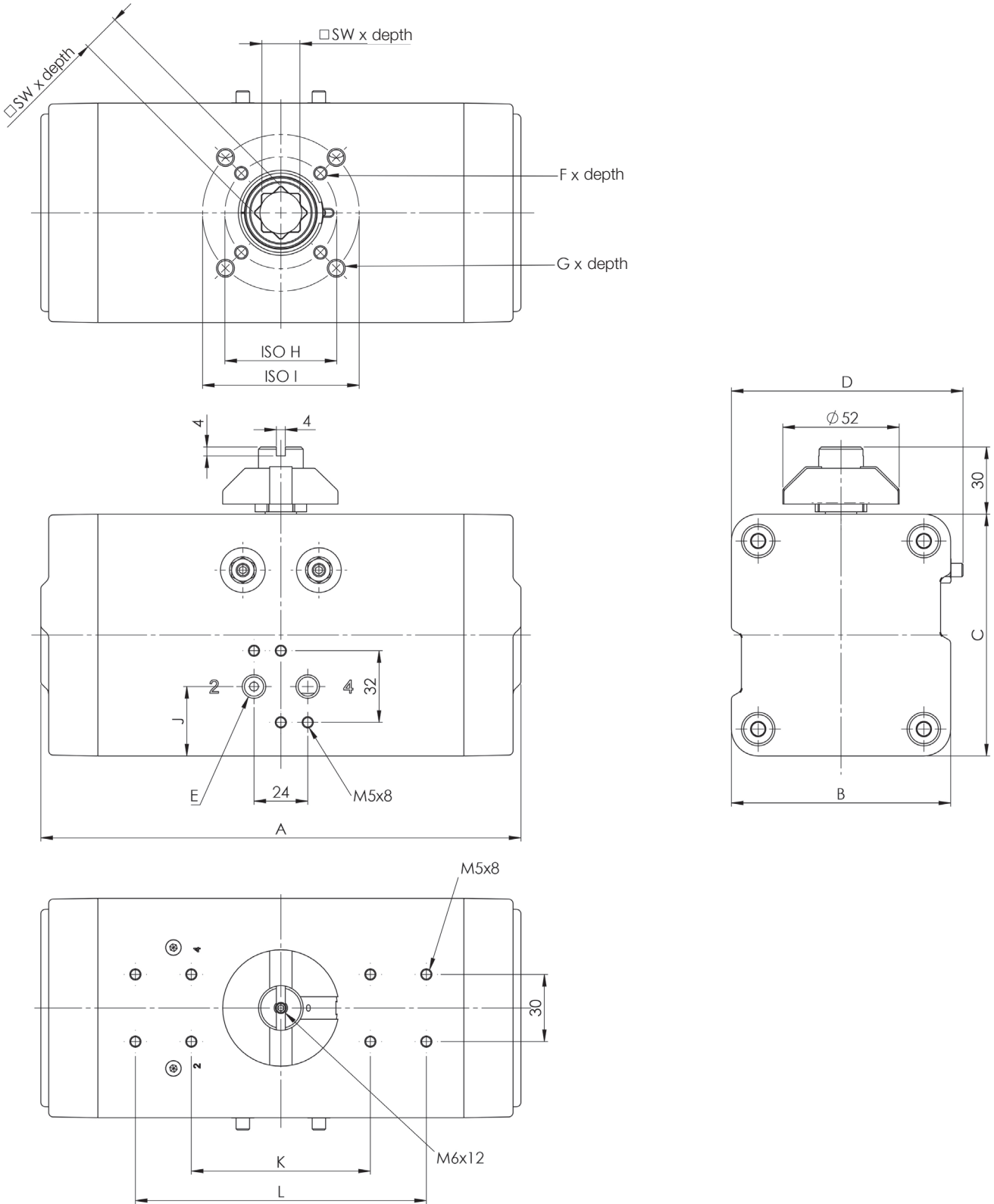

## Drawings for actubar types AD/AS-DV-360 to -1200

Type AD/AS-360 to AD/AS-520

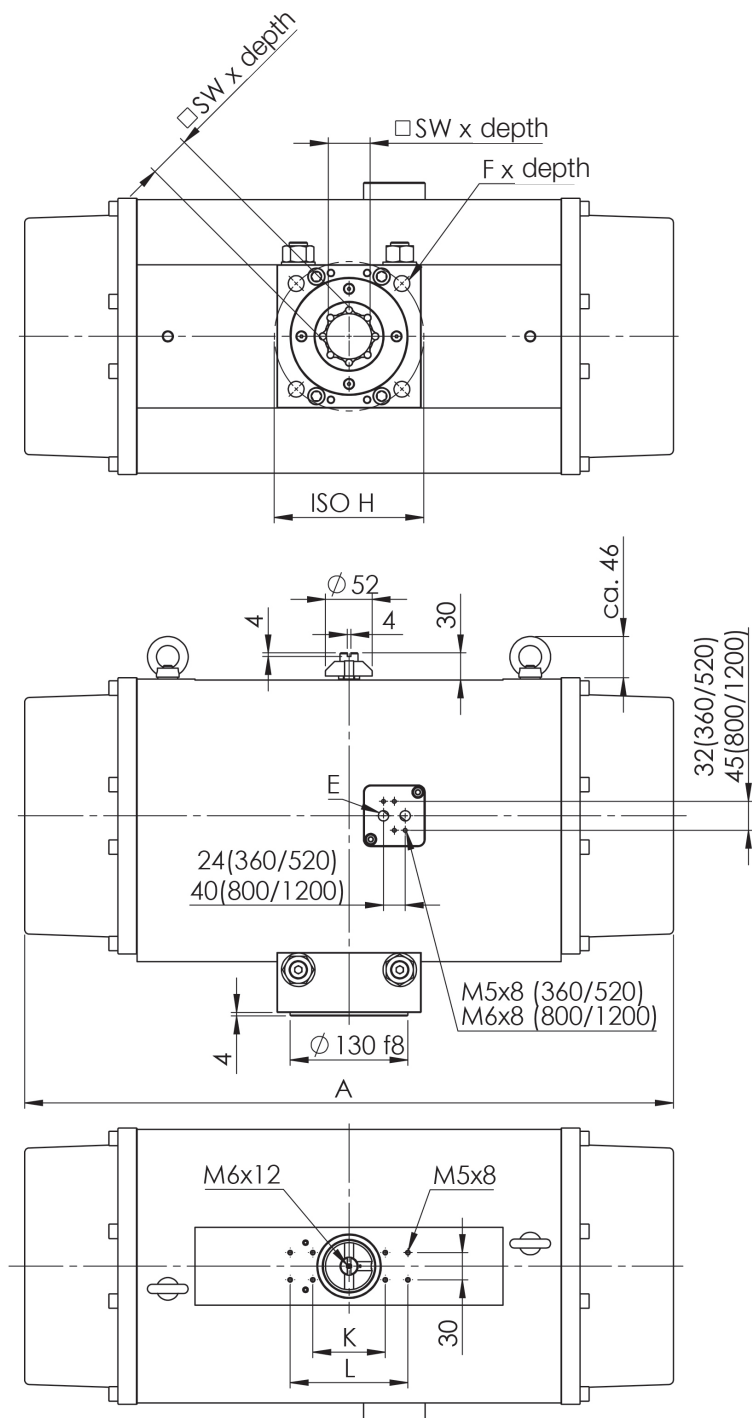

Type AD/AS-800 to AD/AS-1200

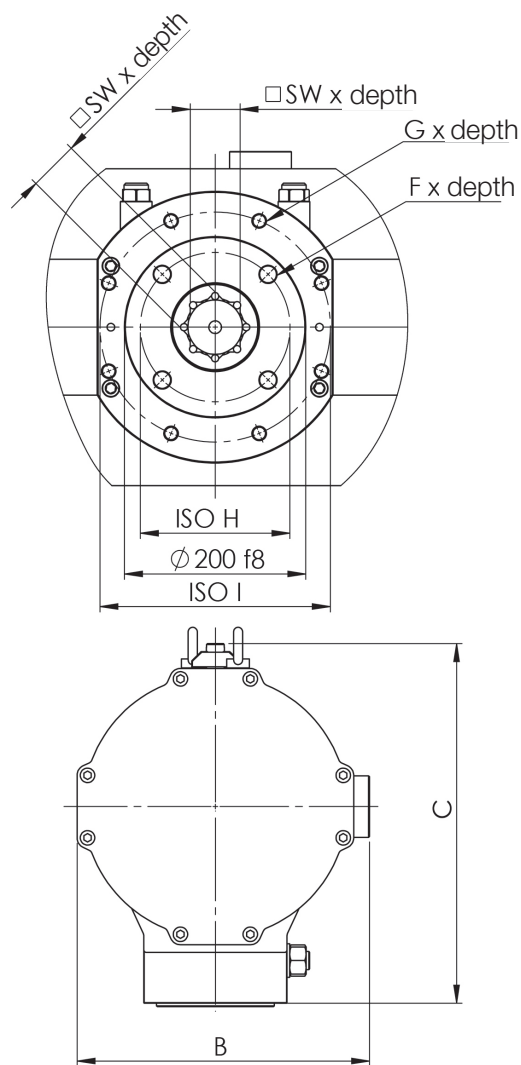

## Table of dimensions AD/AS-DV

Type AD/AS	A	B	C	D	E	F x depth	G x depth	ISO H	ISO I	J	K	L	SW x depth
<b>001</b>	80	45	45		G 1/8"	M5x8		ø36/F03		22,5	50		9x12
<b>002</b>	134	59	59		G 1/8"	M5x8	M6x9	ø36/F03	ø50/F05	27,5	50		11x13
<b>004</b>	144	68	68	82	G 1/8"	M5x8	M6x9	ø36/F03	ø50/F05	24	80		14x17
<b>006</b>	159	76	84	90	G 1/8"	M6x9	M8x12	ø36/F03	ø70/F07	32	80		14x17
<b>008</b>	173	98	108	109	G 1/8"	M6x9	M8x12	ø50/F05	ø70/F07	31	80		14x17
<b>011</b>	215	98	108	109	G 1/8"	M6x9	M8x12	ø50/F05	ø70/F07	31	80	130	17x20
<b>018</b>	213	114	132	127	G 1/4"	M6x9	M8x12	ø50/F05	ø70/F07	36,5	80	130	17x20
<b>026</b>	281	114	132	127	G 1/4"	M8x12	M10x15	ø70/F07	ø102/F10	36,5	80	130	22x25
<b>037</b>	301	138	161	155	G 1/4"	M8x12	M10x15	ø70/F07	ø102/F10	40,5	80	130	22x25
<b>050</b>	347	138	161	155	G 1/4"	M8x12	M10x15	ø70/F07	ø102/F10	40,5	80	130	22x25
<b>076</b>	329	176	200	196	G 1/4"	M10x15	M12x18	ø102/F10	ø125/F12	50	80	130	27x30
<b>110</b>	475	176	200	196	G 1/4"	M10x15	M12x18	ø102/F10	ø125/F12	50	80	130	27x30
<b>160</b>	516	199	220	225	G 1/4"	M10x15	M12x18	ø102/F10	ø125/F12	48	80	130	27x30
<b>230</b>	560	223	244	249	G 1/4"	M16x24		ø140/F14		58	80	130	36x40
<b>360</b>	696	278	320		G 1/4"	M20x30		ø165/F16			80	130	46x50
<b>520</b>	716	323	368		G 1/4"	M20x30		ø165/F16			80	130	46x60
<b>800</b>	725	371	424		G 1/2"	M20x28	M16x30	ø165/F16	ø254/F25			130	55x58
<b>1200</b>	953	431	486		G 1/2"	M16x30		ø254/F25				130	55x58

## Double-acting actuators AD/AS-DV

Type AD	Weight [kg]	Volume/Double-stroke [L]
<b>001</b>	0,34	0,05
<b>002</b>	0,73	0,15
<b>004</b>	1,21	0,25
<b>006</b>	1,81	0,41
<b>008</b>	2,97	0,60
<b>011</b>	3,59	0,85
<b>018</b>	4,80	1,35
<b>026</b>	6,27	1,78
<b>037</b>	8,23	2,75
<b>050</b>	11,25	3,73
<b>076</b>	15,90	5,50
<b>110</b>	22,94	8,50
<b>160</b>	27,46	11,90
<b>230</b>	38,10	16,90
<b>360</b>	55,00	25,00
<b>520</b>	71,00	37,00
<b>800</b>	101,00	53,00
<b>1200</b>	162,20	93,70

## Single-acting actuators AD/AS-DV

Typ AS	Weight* [kg]	Volume/Double-stroke [L]
<b>002</b>	0,84	0,06
<b>004</b>	1,38	0,09
<b>006</b>	2,04	0,19
<b>008</b>	3,13	0,20
<b>011</b>	3,89	0,33
<b>018</b>	5,28	0,50
<b>026</b>	6,93	0,73
<b>037</b>	9,43	1,15
<b>050</b>	12,81	1,63
<b>076</b>	18,66	2,30
<b>110</b>	27,02	3,50
<b>160</b>	33,30	4,80
<b>230</b>	45,20	7,00
<b>360</b>	67,00	10,00
<b>520</b>	90,20	15,00
<b>800</b>	120,20	23,00
<b>1200</b>	212,60	38,10

\* Weight with 12 springs



## Components AD-DV-001 to AD/AS-DV-002

<b>10</b>	Housing	<b>30</b>	Pinion	<b>50</b>	Piston	<b>61</b>	Cap sealing
<b>11<sup>1</sup></b>	Stop screw	<b>32</b>	Top pinion bearing	<b>52</b>	Guide shoe	<b>62</b>	Cap screws
<b>12<sup>1</sup></b>	Sealing stop screw	<b>33<sup>1</sup></b>	Lower pinion bearing	<b>53</b>	Guide ring	<b>70<sup>1</sup></b>	Springs (type AS)
<b>13<sup>1</sup></b>	Disk	<b>35</b>	Upper pinion sealing	<b>54</b>	Piston seal		
<b>14<sup>1</sup></b>	Lock nut	<b>37</b>	Ower pinion sealing	<b>60</b>	Cap		

<sup>1</sup> Not applicable for size 001

## Schematic diagram AD/AS-DV

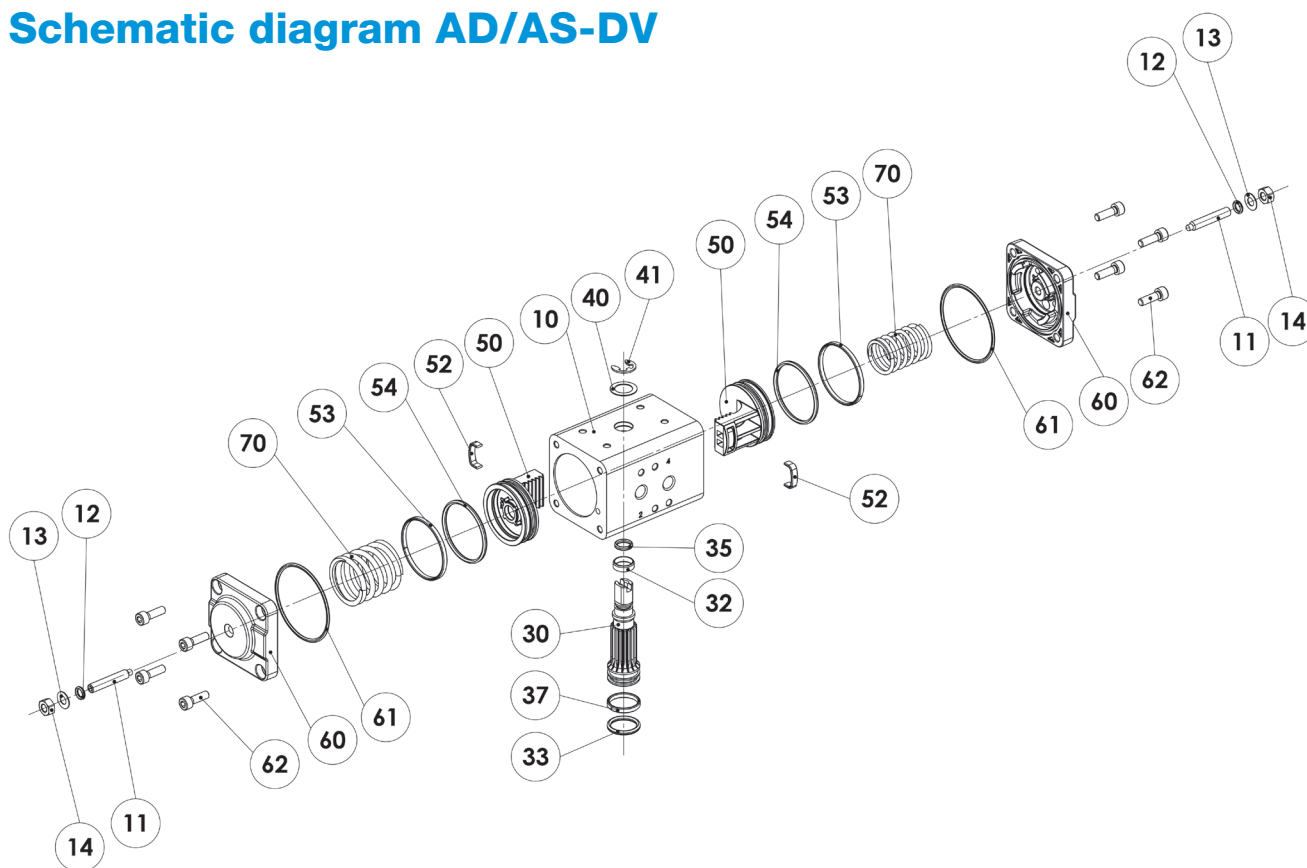

## Components AD/AS-DV-004 to AD/AS-DV-230

10	Housing	17	Position indicator	32	Top pinion bearing	53	Guide ring
11	Stop screw	18	Vacotrol sealing screw	33	Lower pinion bearing	54	Piston seal
12	Sealing stop screw	19	Position indication balls	35	Upper pinion sealing	60	Cap
13	Disk	24	Vacotrol sealing	37	Lower pinion sealing	61	Cap sealing
14	Lock nut	25 <sup>1</sup>	Ring nut	38	Circular wire ring	62	Cap screws
15	Threaded pin	30	Pinion	50	Piston	70	Springs (type AS)
16	Namur shaft	31	Stop cams	52	Guide shoe		

<sup>1</sup> Size 160-230 (slings from AD/AS-160)

### Schematic diagram AD/AS-DV

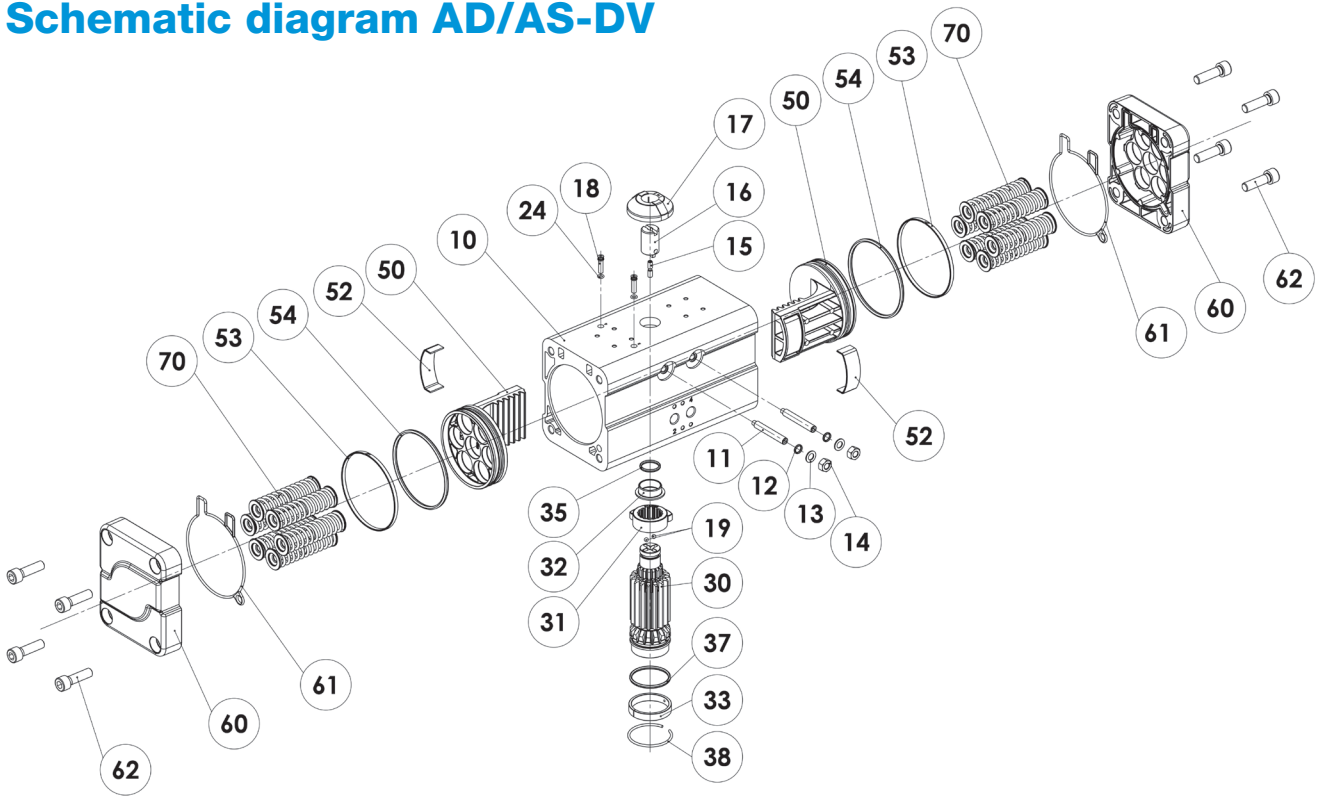

## Components AD/AS-DV-360 to AD/AS-DV-1200





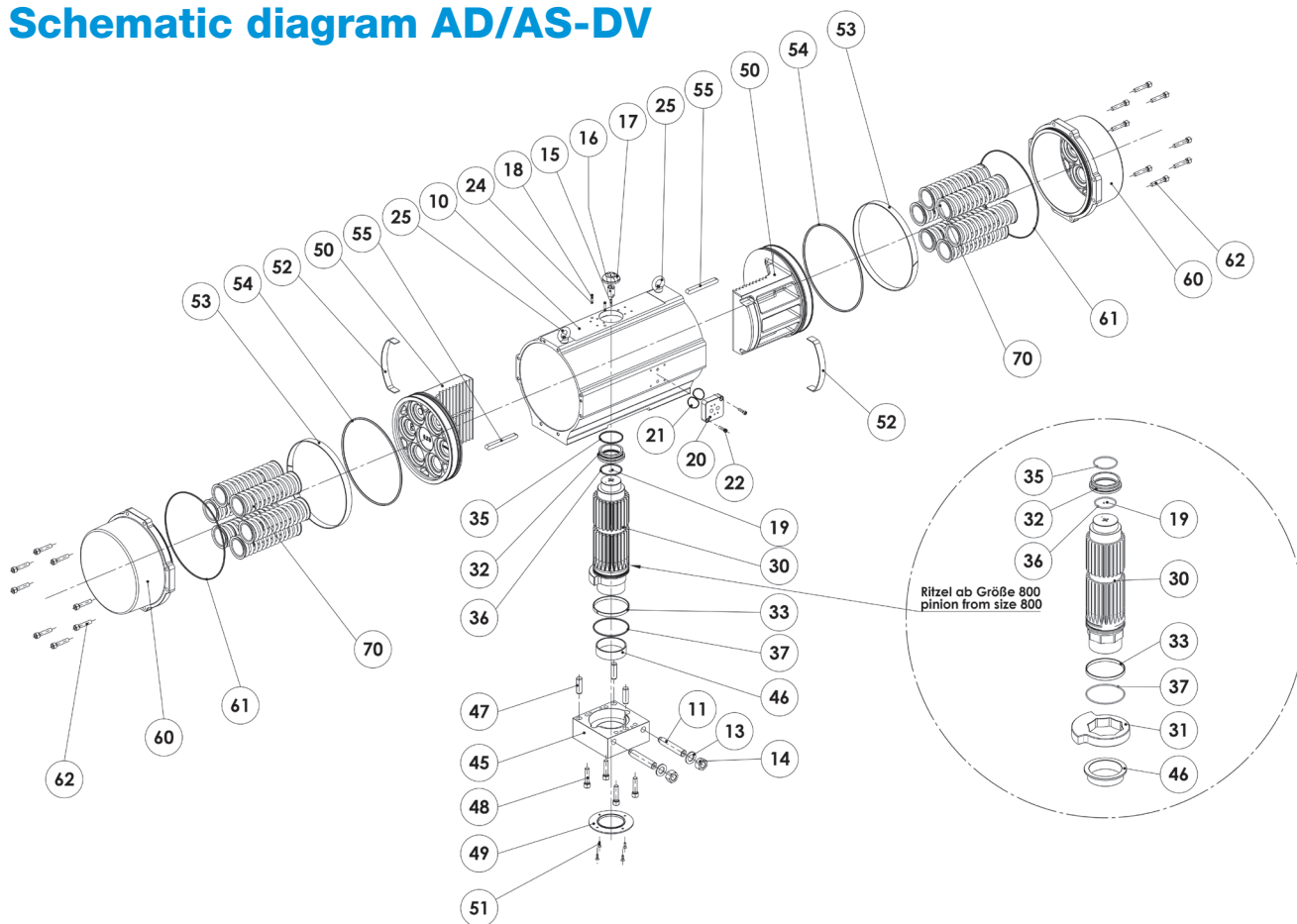

<b>10</b>	Housing	<b>20</b>	Namur adapter plate	<b>35</b>	Upper pinion sealing	<b>51<sup>2</sup></b>	Countersunk screws
<b>11</b>	Stop screw	<b>21</b>	Sealing	<b>36</b>	Sealing upper layer	<b>52</b>	Guide shoe
<b>13<sup>1</sup></b>	Disk	<b>22</b>	Screws	<b>37</b>	Lower pinion sealing	<b>53</b>	Guide ring
<b>14</b>	Lock nut	<b>24</b>	Vacotrol sealing	<b>45</b>	Flange plate	<b>54</b>	Piston seal
<b>15</b>	Threaded pin	<b>25</b>	Ring nut	<b>46</b>	Bearing flange plate	<b>55</b>	Feather key
<b>16</b>	Namur shaft	<b>30</b>	Pinion	<b>47</b>	Straight pins	<b>60</b>	Cap
<b>17</b>	Position indicator	<b>31<sup>2</sup></b>	Stop cams	<b>48</b>	Flange screws	<b>61</b>	Cap sealing
<b>18</b>	Vacotrol sealing screw	<b>32</b>	Top pinion bearing	<b>49<sup>2</sup></b>	Centering ring	<b>62</b>	Cap screws
<b>19</b>	Position indication balls	<b>33</b>	Lower pinion bearing	<b>50</b>	Piston	<b>70</b>	Springs (type AS)

<sup>1</sup> Not applicable for size 360-520 | <sup>2</sup> Not applicable for size 800-1200

### Schematic diagram AD/AS-DV



## Mounting variations AD/AS-DV

2/2-way-valve	Drive pinion	Function	Mounting type	2/2-way-valve	Drive pinion	Function	Mounting type
 Butterfly valve	Double D = Z (upon request) 	single-acting spring force closed	A	 Ball valve and Cock valve	Double D = Z (upon request) 	single-acting spring force closed	A
		single-acting spring force open	D			single-acting spring force open	D
	Octagonal = V 	single-acting spring force closed	F		Octagonal = V 	single-acting spring force closed	F
		single-acting spring force open	H			single-acting spring force open	H

## Ordering code (example) AD/AS-DV

<table border="1"> <tr><td>A</td><td>S</td></tr> </table> Function S = single D = double	A	S	-	<table border="1"> <tr><td>D</td><td>V</td></tr> </table> Certificate	D	V	-	<table border="1"> <tr><td>0</td><td>5</td><td>0</td></tr> </table> Type	0	5	0	/	<table border="1"> <tr><td>0</td><td>9</td><td>0</td></tr> </table> Pivoting angle 90°	0	9	0	-	<table border="1"> <tr><td>0</td><td>8</td></tr> </table> No. springs	0	8	-	<table border="1"> <tr><td>V22</td></tr> </table> Pinion model*	V22	-	<table border="1"> <tr><td>F</td></tr> </table> Mounting type Page 3	F
A	S																									
D	V																									
0	5	0																								
0	9	0																								
0	8																									
V22																										
F																										
<table border="1"> <tr><td>A</td><td>D</td></tr> </table> Function S = single D = double	A	D	-	<table border="1"> <tr><td>D</td><td>V</td></tr> </table> Certificate	D	V	-	<table border="1"> <tr><td>0</td><td>5</td><td>0</td></tr> </table> Type	0	5	0	/	<table border="1"> <tr><td>0</td><td>9</td><td>0</td></tr> </table> Pivoting angle 90°	0	9	0	-	<table border="1"> <tr><td>Z...</td></tr> </table> No. springs	Z...	-	<table border="1"> <tr><td>Z...</td></tr> </table> Pinion model*	Z...	-	<table border="1"> <tr><td>A</td></tr> </table> Mounting type Page 3	A	
A	D																									
D	V																									
0	5	0																								
0	9	0																								
Z...																										
Z...																										
A																										

\* V = octagonal with measurements    Z = double-D with dimensions given

## DNV-Certificate AD/AS-DV



**DNV**

Certificate No:  
**TAP00002EK**  
Revision No:  
1

### TYPE APPROVAL CERTIFICATE

**This is to certify:**  
That the Pneumatic Actuator

with type designation(s)  
**AD-DV-001 up to AD-DV-1200, AS-DV-002 up to AS-DV-1200**

Issued to  
**bar pneumatische Steuerungssysteme GmbH**  
Dattenberg, Rheinland-Pfalz, Germany

is found to comply with  
DNV rules for classification – Ships Pt.4 Ch.6 Piping systems

**Application :**  
Products approved by this certificate are accepted for installation on all vessels classed by DNV.

**Type**  
AD-DV-001 up to AD-DV-1200 see certificate  
AS-DV-002 up to AS-DV-1200 see certificate

**Dsgn. press./Torque**  
see certificate  
see certificate

Issued at **Hamburg** on **2021-12-21**

This Certificate is valid until **2026-09-29**.  
DNV local station: **Essen**

Approval Engineer: **Ana Cristina Do Carmo Insfran**

for **DNV**  
Digitally Signed By: **Schwab, Wolfgang**  
Location: **DNV OS-ES Hamburg, Germany**  
Signing Date: **22.12.2021** on behalf of



**Olaf Drews**  
Head of Section

This Certificate is subject to terms and conditions overlaid. Any significant change in design or construction may render this Certificate invalid. The validity date relates to the Type Approval Certificate and not to the approval of equipment/systems installed.

LEGAL DISCLAIMER: Unless otherwise stated in the applicable contract with the holder of this document, or following from mandatory law, the liability of DNV AS, its parent companies and their subsidiaries as well as their officers, directors and employees ("DNV") arising from or in connection with the services rendered for the purpose of the issuance of this document or reliance thereon, whether in contract or in tort (including negligence), shall be limited to direct losses and under any circumstances be limited to 500,000 USD.

Form code: TA-251      Revision: 2021-03      www.dnv.com      Page 1 of 3

## bar-vacotrol® – The modules of the system family



**bar-positrol®**  
Electro-pneumatic positioner



**bar-positurn2**  
Electro-pneumatic positioner  
and 3-position control device



**bar-valve&switch**  
Feedback system with integrated  
control valves



**bar-positswitch**  
Opto-electrical feedback system



**bar-positfixx-A**  
Air guide plates for positioner  
Type TZID (ABB)



**bar-positfixx-S**  
Air guide plates for positioner  
Type SIPART PS2 (Siemens)





---

The descriptions and photographs contained in this product specification sheet are supplied by way of information only and are not binding.  
bar GmbH reserves the right to carry out any technical and design improvements to its products without prior notice.  
Warranty: All sales and contracts for sale are expressly conditioned on the buyer's assent to bar GmbH terms and conditions found on its website at [www.bar-gmbh.de](http://www.bar-gmbh.de).  
bar GmbH hereby objects to any term, different from or additional to bar GmbH terms, contained in any buyer communication in any form,  
unless agreed to in a writing signed by an officer of bar GmbH.

---



---

**bar pneumatische Steuerungssysteme GmbH**  
Auf der Hohl 1 • 53547 Dattenberg • Germany  
Tel. +49 (0) 2644 96070 • Fax +49 (0) 2644 960735  
[bar-info@wattswater.com](mailto:bar-info@wattswater.com) • [www.bar-gmbh.de](http://www.bar-gmbh.de)